

New

HYDRAULIC GEAR
PUMPS AND
MOTORS

POLARIS[®]

○ **Modification from former edition.**

FEATURES

The new gear pumps and motors "PH" series is an evolution of the "POLARIS" series.

"POLARIS PH" has a new body made of cast iron to have higher operating parameters and keep the full POLARIS versatility regarding shafts, flanges, ports and built-in valves.

This project is targeted for forklifts, skid steer loaders and all those applications where traditional aluminum pumps are being pushed close to their limits.

The possibility to mate the body with the cast iron covers further reduces noise levels, in addition to increasing strength.

- High working pressure also for high displacements
- Long service life
- Low noise level
- High volumetric efficiency also at high temperature
- Inlet & outlet optimization - High speed
- High versatility due to Polaris 20 family components
- Combination in multiple pumps
- Built-in valves simplify circuit design

Construction	Heavy duty external gear pumps and motors 3-piece construction
Mounting	EUROPEAN - SAE - GERMAN standard flanges
Line connection	Threaded or split flange
Direction of rotation (looking on drive shaft)	Anti-clock (S) - clockwise (D) - reversible external drain (L - R) reversible internal drain (B)
Inlet pressure range for pumps	10 ÷ 44 psi [0,7 ÷ 3 bar (abs.)]
Max back pressure for single rotation motors and reversible internal drain motors	p_1 (continuous) max 73 psi (5 bar) #
	p_2 (for 20 s) max 116 psi (8 bar) #
	p_3 (for 8 s) max 218 psi (15 bar) #
Max drain line pressure on the reversible rotation motors	73 psi (5 bar) #
Max back pressure on the series motors (reversible motors external drain)	2175 psi (150 bar)
Fluid temperature range	See table (1)
Fluid	Mineral oil based hydraulic fluids to ISO/DIN. For other fluids please consult our technical sales department.
Viscosity range	From 60 to 456 SSU [12 to 100 mm ² /s (cSt)] recommended
	Up to 3410 SSU [750 mm ² /s (cSt)] permitted
Filtering requirement	See table (2) page 2

The pressure stated in the table can vary in relation to the shaft speed rotation.

01/06.2009

FEATURES

Tab. 1

Type	Fluid composition	Max pressure psi - (bar)	Max speed min ⁻¹	Temperature °F - (°C)			Seals (●)	Special shaft seals (◆)
				Min	Max continuous	Max peak		
ISO/DIN	Mineral oil based hydraulic fluid to ISO/DIN	See page 4	See page 4	-40 (-40)	176 (80)	212 (100)	N	D - H - C
				-13 (-25)	230 (110)	257 (125)	V	D

(●) **N**= Buna N (standard) - **V**= Viton

◆ Shaft seals max relative pressure and mounting scheme

	D	H	C
	Standard shaft seal with wiper seal	High pressure special shaft seal	High pressure special shaft seal with wiper seal
Single rotation pumps	Max 44 psi (3 bar) # DCAT_033_037	Max 363 psi (25 bar) # DCAT_033_039	Max 363 psi (25 bar) # DCAT_033_036
Single rotation motors	Max 44 psi (3 bar) # DCAT_033_038		
Reversible rotation pumps and motors			

The pressure stated in the table can vary in relation to the shaft speed rotation.
For more information please consult our technical sales department.

Filtration

Tab. 2

Working pressure psi (bar)	$\Delta p < 2030$ $\Delta p < (140)$	$2030 < \Delta p < 3045$ $(140) < \Delta p < (210)$	$\Delta p > 3045$ $\Delta p > (210)$
Contamination class NAS 1638	10	9	8
Contamination class ISO 4406	21/19/16	20/18/15	19/17/14
Achieved with filter $Bx_{(c)} \geq 75$	25 μm	10 μm	10 μm

Casappa recommends to use
its own production filters:



Definition of rotation direction looking on the drive shaft

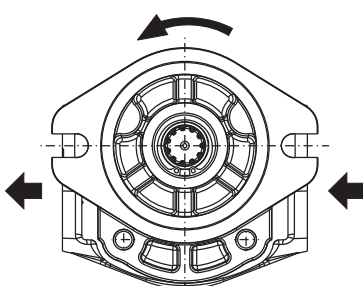

Anti-clock rotation

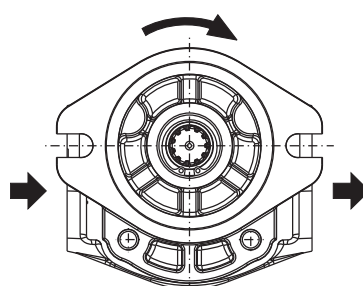

Clockwise rotation

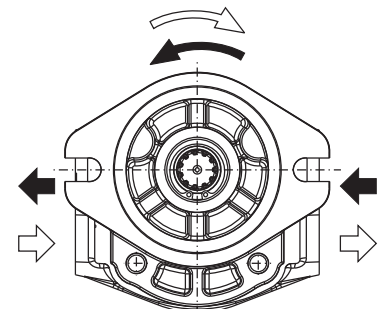

Reversible rotation

01/06.2009

GENERAL DATA PUMPS AND MOTORS

Pressure definition

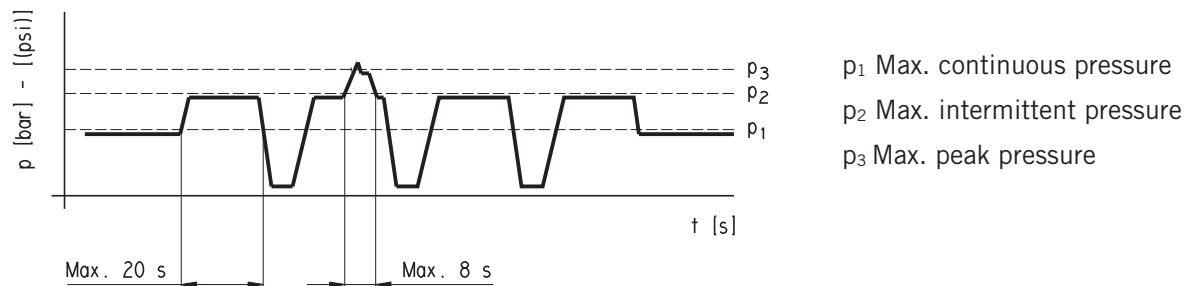

Pump type PHP Motor type PHM	Displacement in ³ /rev (cm ³ /rev)	Max. pressure			Max. speed min ⁻¹	Min. speed
		p ₁	p ₂	p ₃		
		psi (bar)				
PH. 20•19	1.16 (19,09)	3625 (250)	4060 (280)	4350 (300)	3500	500
PH. 20•20	1.29 (21,14)	3625 (250)	4060 (280)	4350 (300)	3500	500
PH. 20•23	1.42 (23,32)	3625 (250)	4060 (280)	4350 (300)	3000	500
PH. 20•24,5	1.52 (24,84)	3335 (230)	3770 (260)	4060 (280)	3000	500
PH. 20•25	1.61 (26,42)	3335 (230)	3770 (260)	4060 (280)	3000	500
PH. 20•27,8	1.72 (28,21)	2900 (200)	3335 (230)	3625 (250)	2500	500
PH. 20•31,5	2.01 (33,03)	2900 (200)	3335 (230)	3625 (250)	2500	500

The values in the table refer to unidirectional pumps and motors.
Reversible pump and motors max pressures are 15% lower than those shown in table.
For different working conditions please consult our sales department.

01/06.2009

GENERAL DATA PUMPS AND MOTORS

Q	US gpm (l/min)	Flow
M	lbf in (Nm)	Torque
P	HP (kW)	Power
V	in ³ /rev (cm ³ /rev)	Displacement
n	min ⁻¹	Speed
Δp	psi (bar)	Pressure

Efficiencies

		Pumps	Motors
$\eta_v = \eta_v(V, \Delta p, n)$	Volumetric efficiency	(≈ 0,97)	(≈ 0,96)
$\eta_m = \eta_m(V, \Delta p, n)$	Mechanical efficiency	(≈ 0,88)	(≈ 0,85)
$\eta_t = \eta_v \cdot \eta_m$	Overall efficiency	(≈ 0,85)	(≈ 0,82)

DESIGN CALCULATIONS FOR PUMP

$$Q = V(\text{cm}^3/\text{rev}) \cdot \eta_v \cdot n \cdot 10^{-3} \quad [\text{l/min}]$$

$$M = \frac{\Delta p (\text{bar}) \cdot V (\text{cm}^3/\text{rev})}{62,83 \cdot \eta_m} \quad [\text{Nm}]$$

$$P = \frac{\Delta p (\text{bar}) \cdot V (\text{cm}^3/\text{rev}) \cdot n}{600 \cdot 1000 \cdot \eta_t} \quad [\text{kW}]$$

DESIGN CALCULATIONS FOR MOTOR

$$Q = \frac{V (\text{cm}^3/\text{rev}) \cdot n \cdot 10^{-3}}{\eta_v} \quad [\text{l/min}]$$

$$M = \frac{\Delta p (\text{bar}) \cdot V (\text{cm}^3/\text{rev}) \cdot \eta_m}{62,83} \quad [\text{Nm}]$$

$$P = \frac{\Delta p (\text{bar}) \cdot V (\text{cm}^3/\text{rev}) \cdot n \cdot \eta_t}{600 \cdot 1000} \quad [\text{kW}]$$

01/06.2009

PUMPS NOISE LEVEL REDUCTION

POLARIS PH series reduces the noise level emission.

For more information please consult our technical sales department.

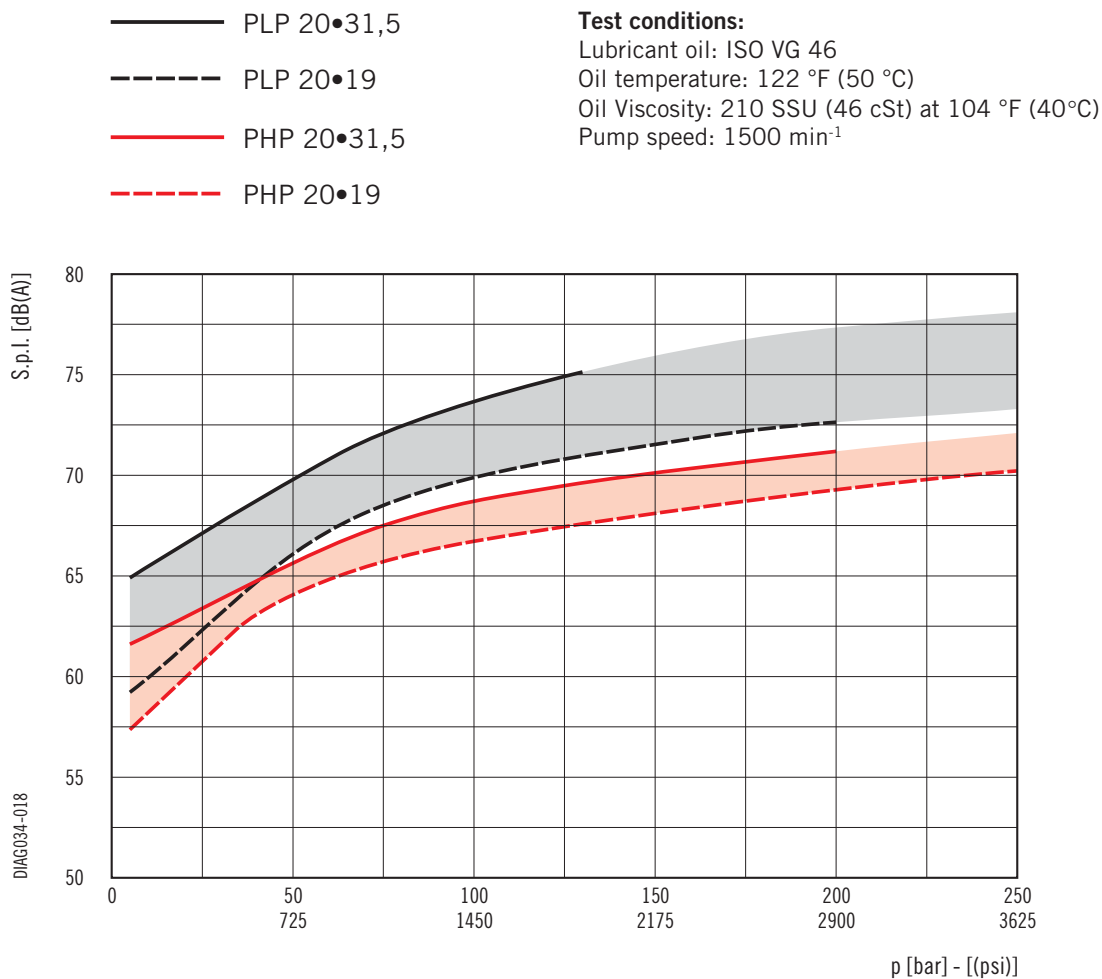

01/06.2009

GEAR PUMPS PERFORMANCE CURVES

Each curve has been obtained at 122 °F (50°C), using oil with viscosity 210 SSU (46 cSt) at 104 °F (40°C) and at these pressures.

PHP 20•19 . . . 290-3625 psi (20-250 bar)
 PHP 20•23 . . . 290-3625 psi (20-250 bar)
 PHP 20•25 . . . 290-3335 psi (20-230 bar)
 PHP 20•31,5 . 290-2900 psi (20-200 bar)

PHP 20•20 . . . 290-3625 psi (20-250 bar)
 PHP 20•24,5 . 290-3335 psi (20-230 bar)
 PHP 20•27,8 . 290-2900 psi (20-200 bar)

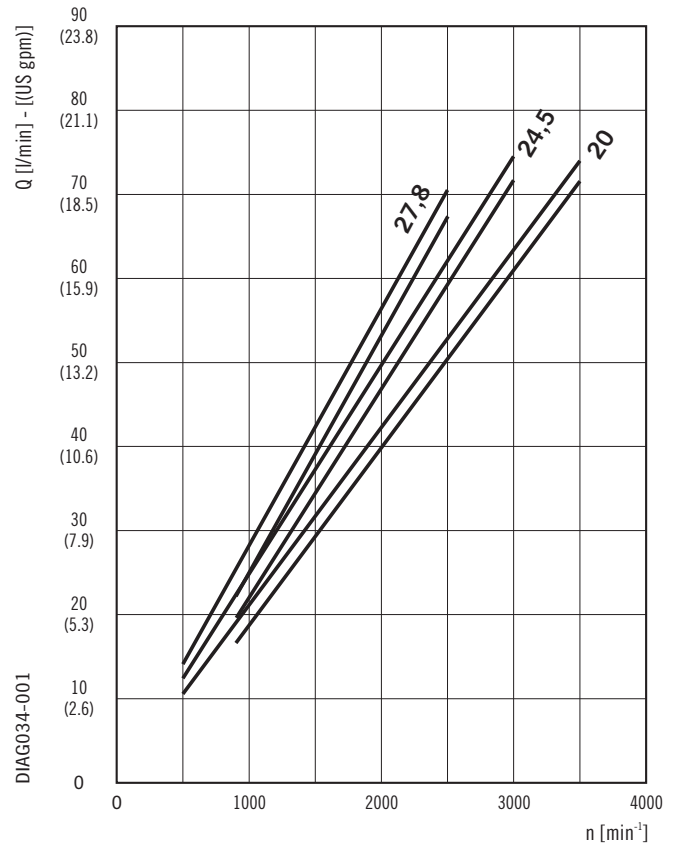
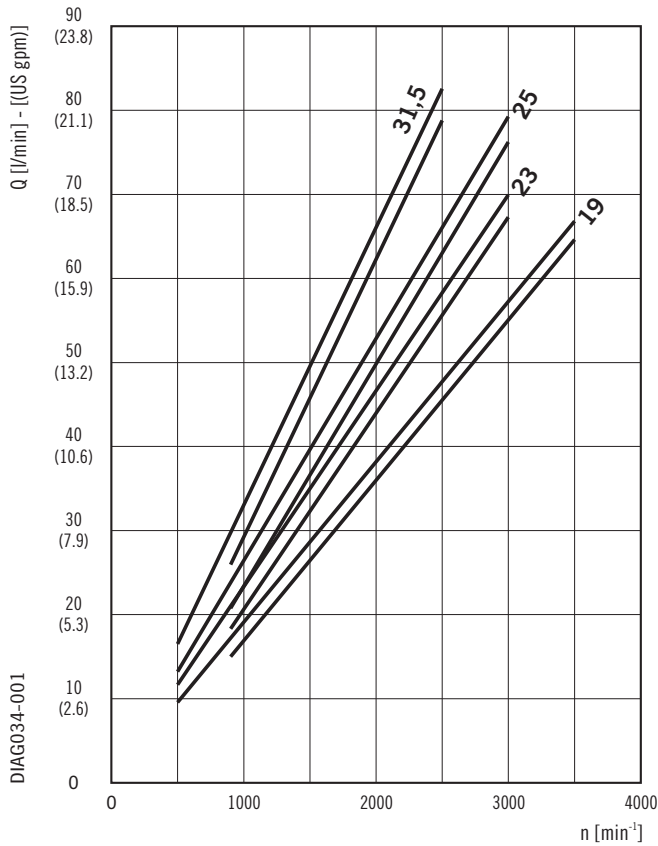

01/06.2009

GEAR PUMPS PERFORMANCE CURVES

PHP 20•19

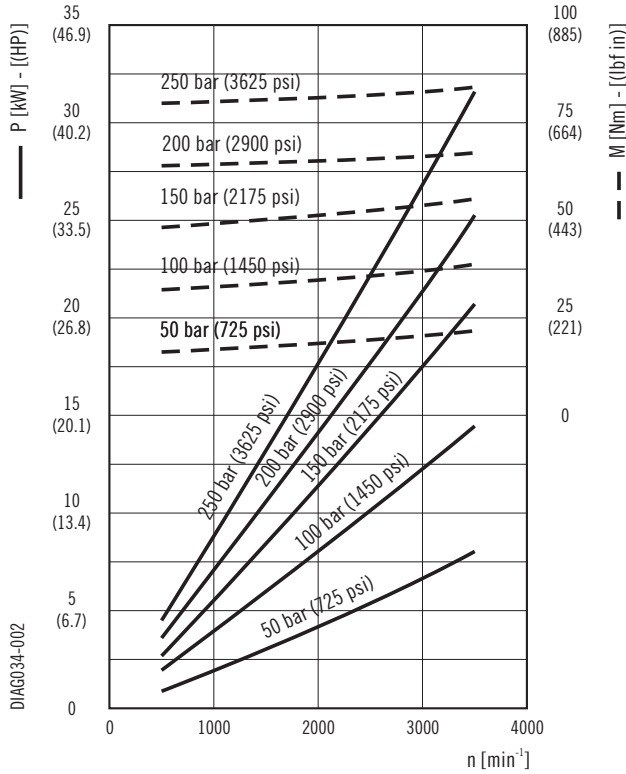

PHP 20•20

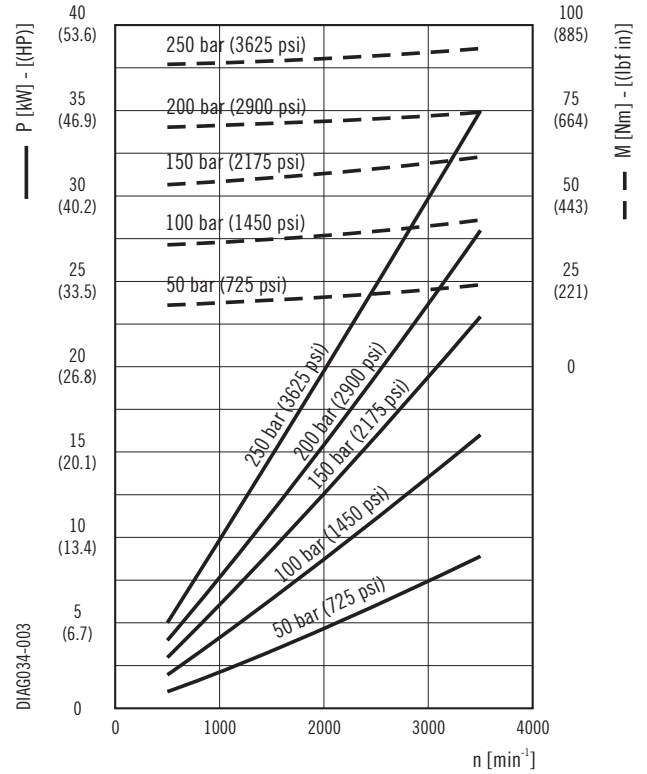

PHP 20•23

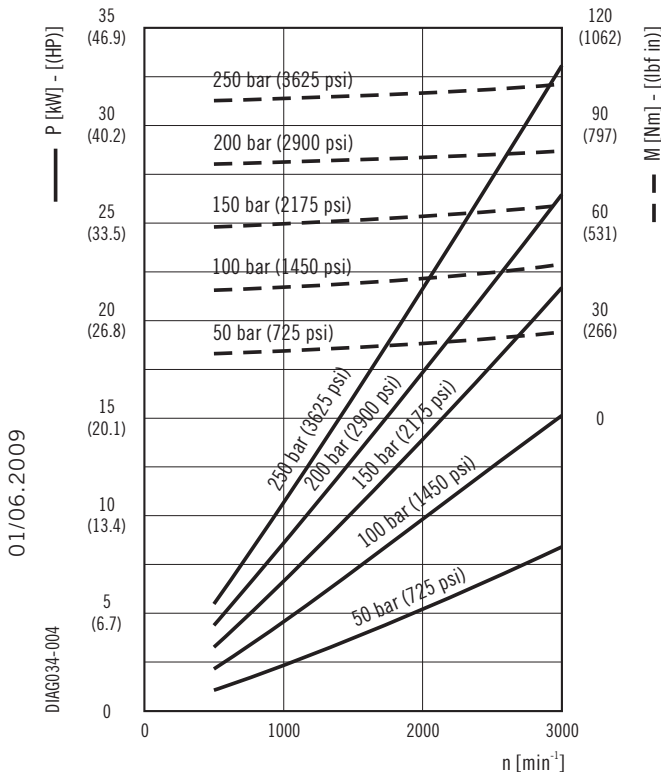

PHP 20•24,5

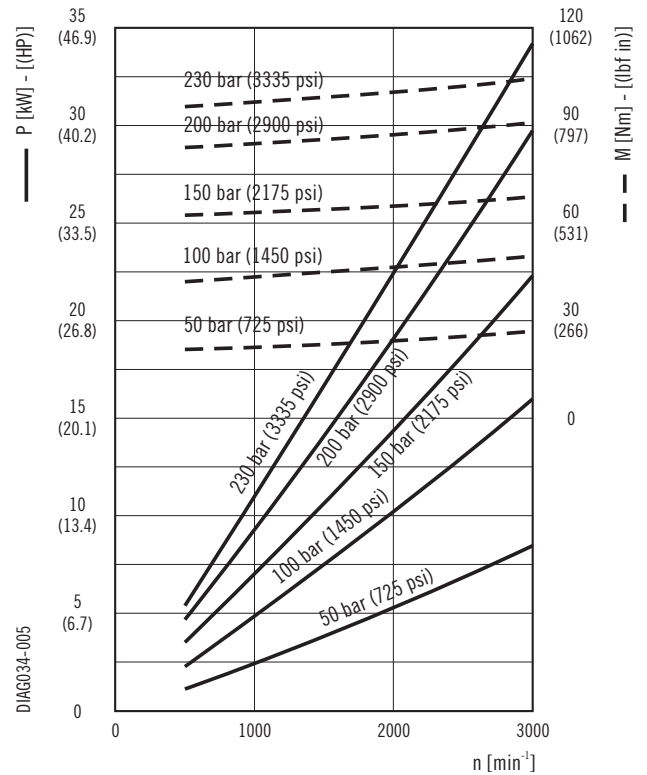

01/06.2009

GEAR PUMPS PERFORMANCE CURVES

PHP 20•25

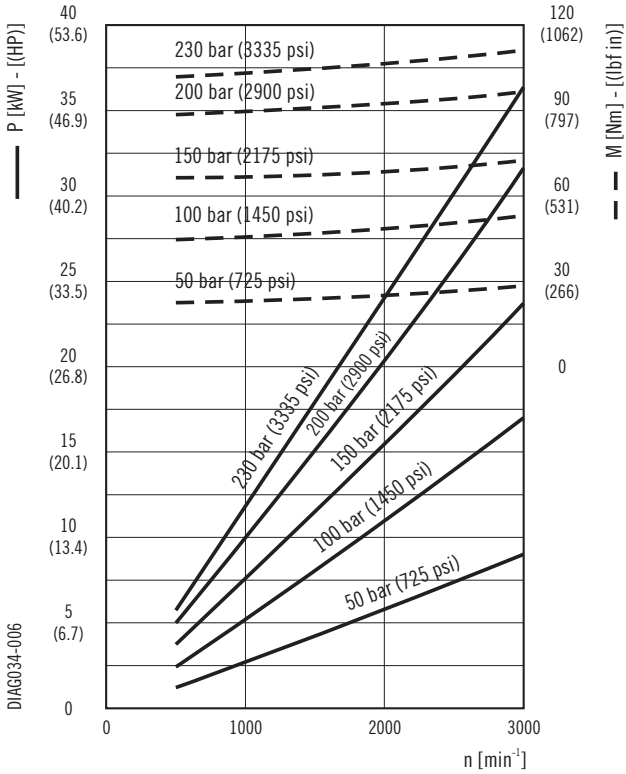

PHP 20•27,8

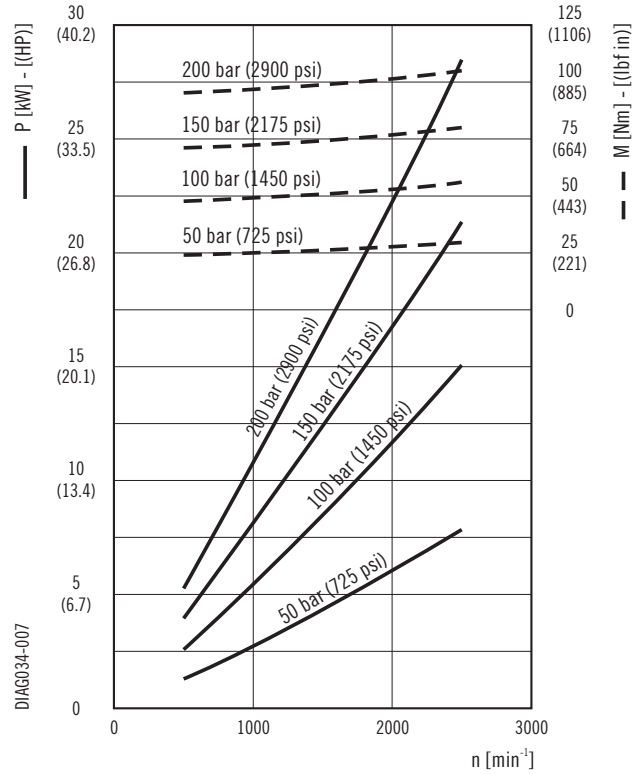

PHP 20•31,5

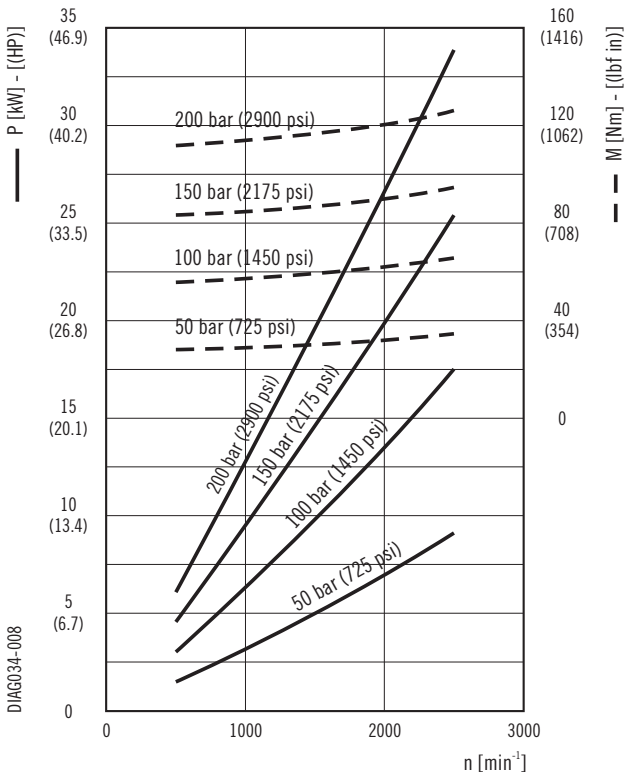

01/06.2009

GEAR MOTORS PERFORMANCE CURVES

Each curve has been obtained at 122 °F (50°C), using oil with viscosity 210 SSU (46 cSt) at 104 °F (40°C) and at these pressures.

PHM 20•19 . . 290-3625 psi (20-250 bar)
 PHM 20•23 . . 290-3625 psi (20-250 bar)
 PHM 20•25 . . 290-3335 psi (20-230 bar)
 PHM 20•31,5 . 290-2900 psi (20-200 bar)

PHM 20•20 . . 290-3625 psi (20-250 bar)
 PHM 20•24,5 . 290-3335 psi (20-230 bar)
 PHM 20•27,8 . 290-2900 psi (20-200 bar)

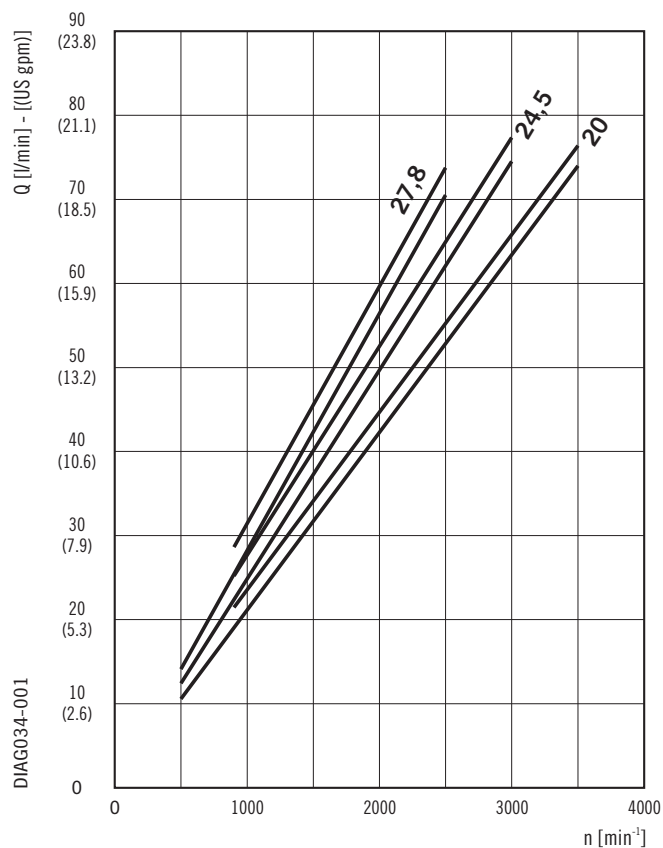
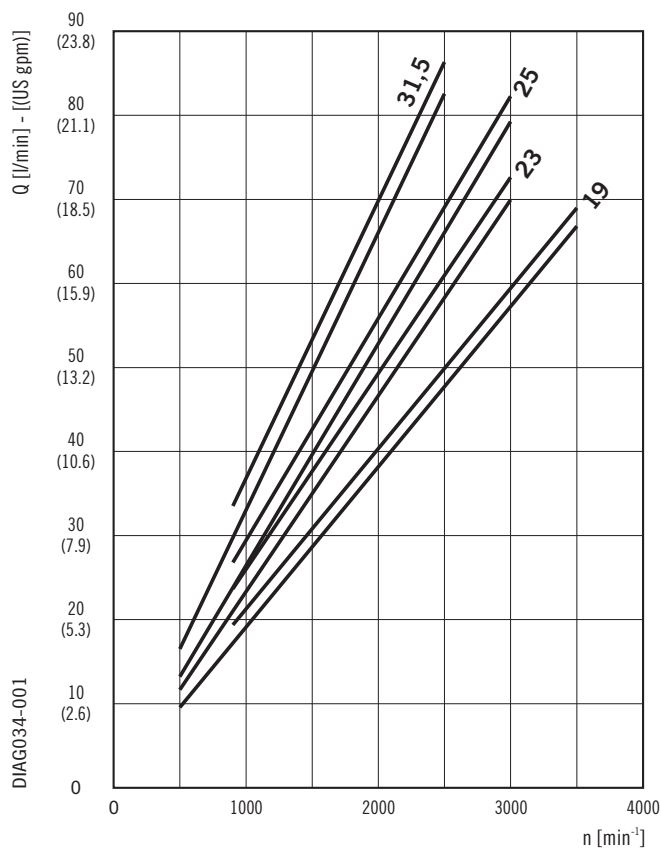

01/06.2009

GEAR MOTORS PERFORMANCE CURVES

PHM 20•19

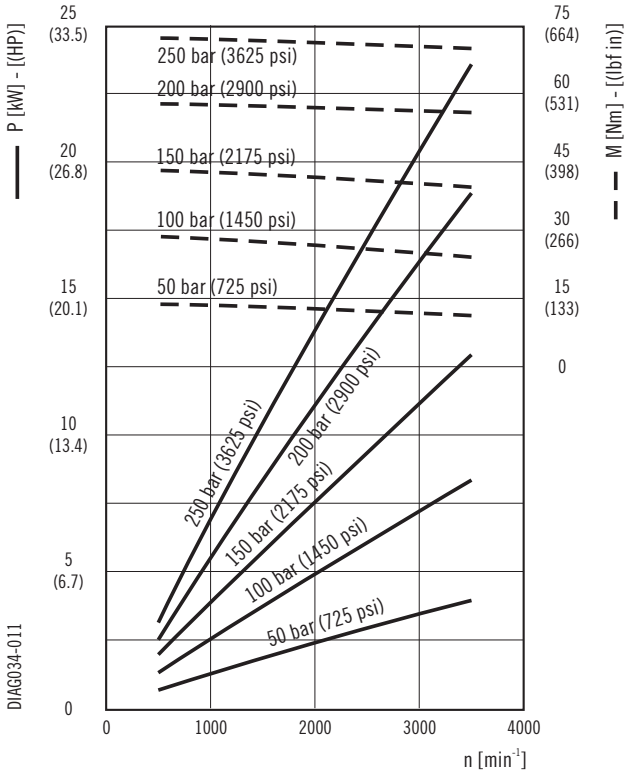

PHM 20•20

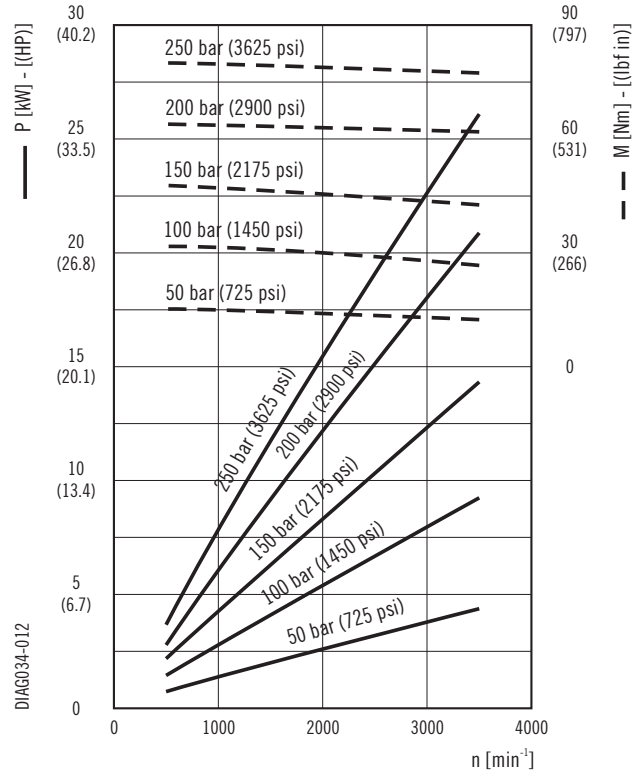

PHM 20•23

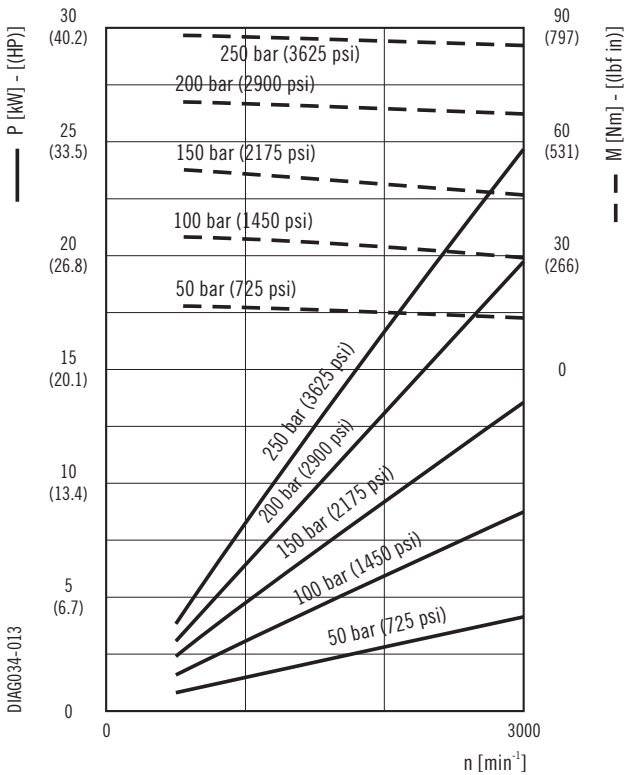

PHM 20•24,5

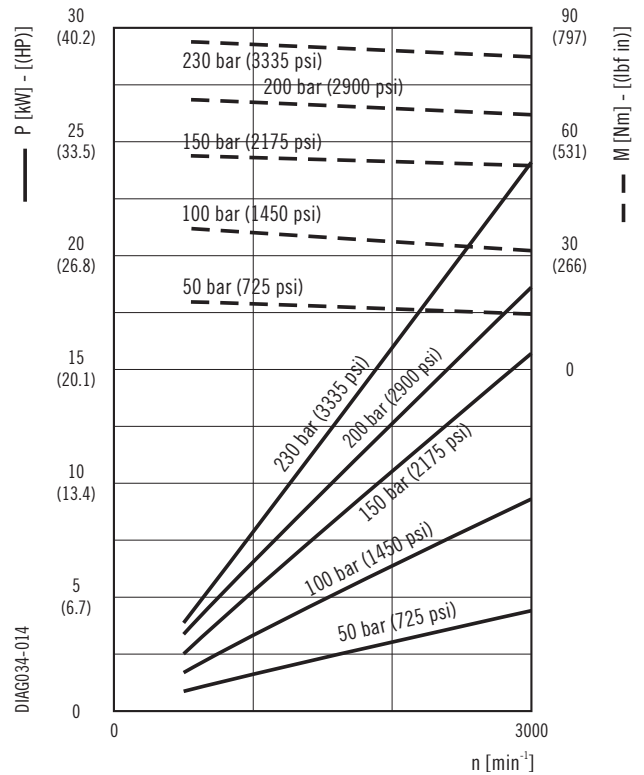

01/06.2009

GEAR MOTORS PERFORMANCE CURVES

PHM 20•25

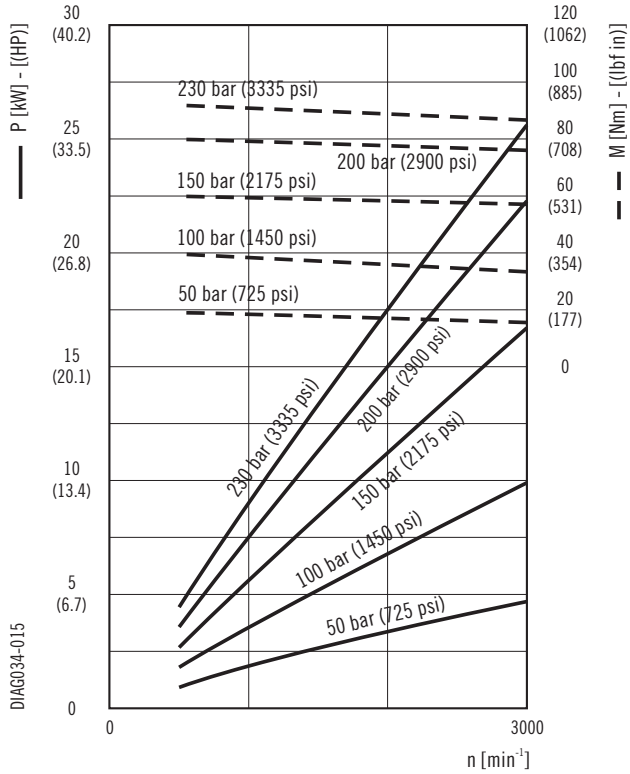

PHM 20•27,8

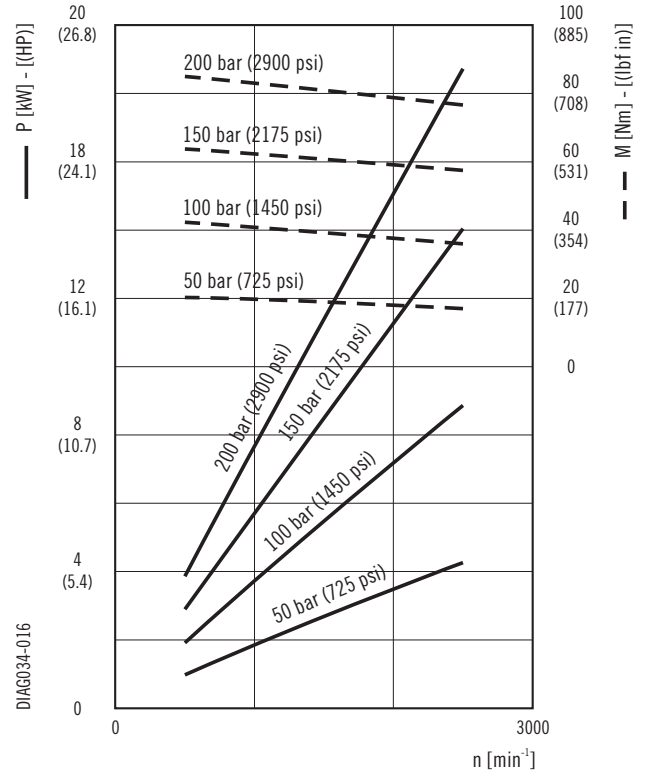

PHM 20•31,5

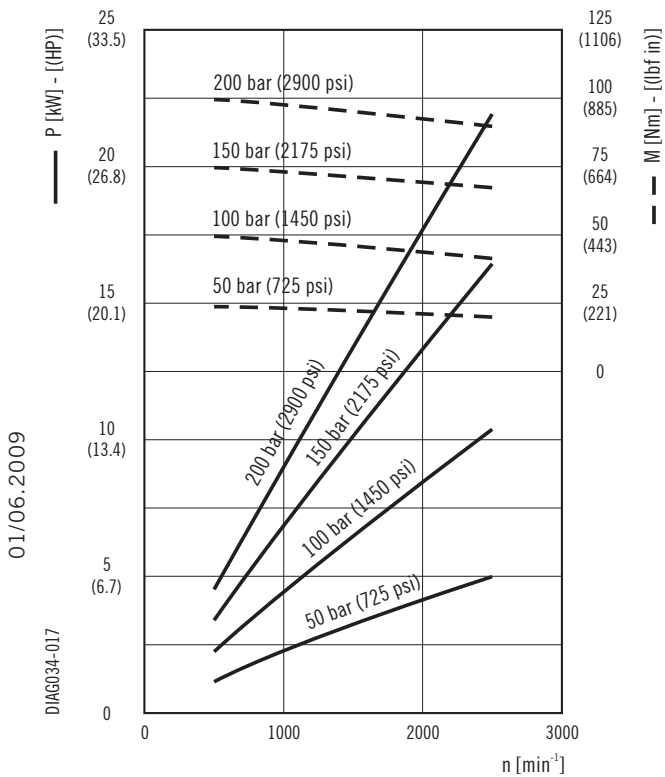

01/06.2009

PH 20

SINGLE UNITS SIDE PORTS

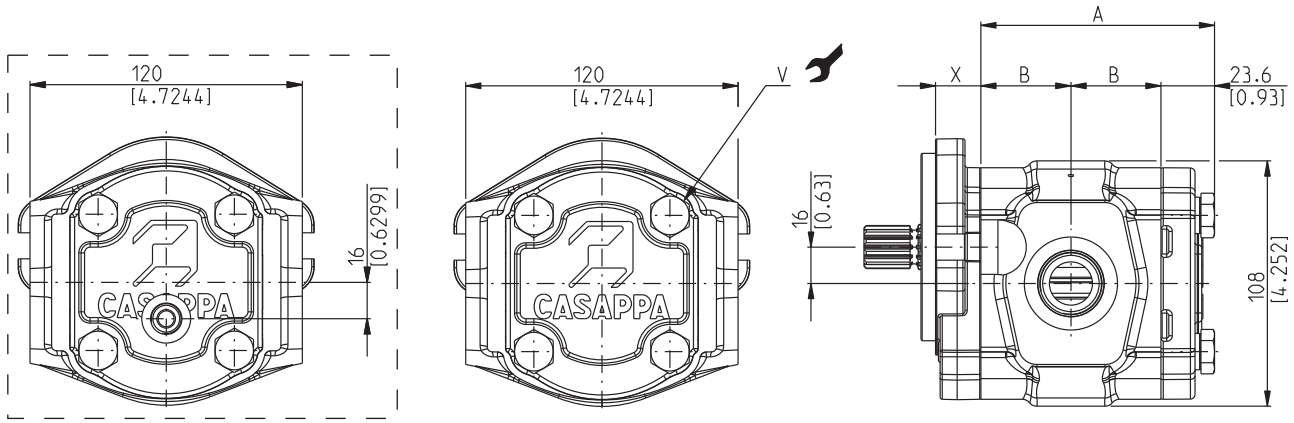

Reversible R

Single rotation S - D and Reversible B

DCAT034-002

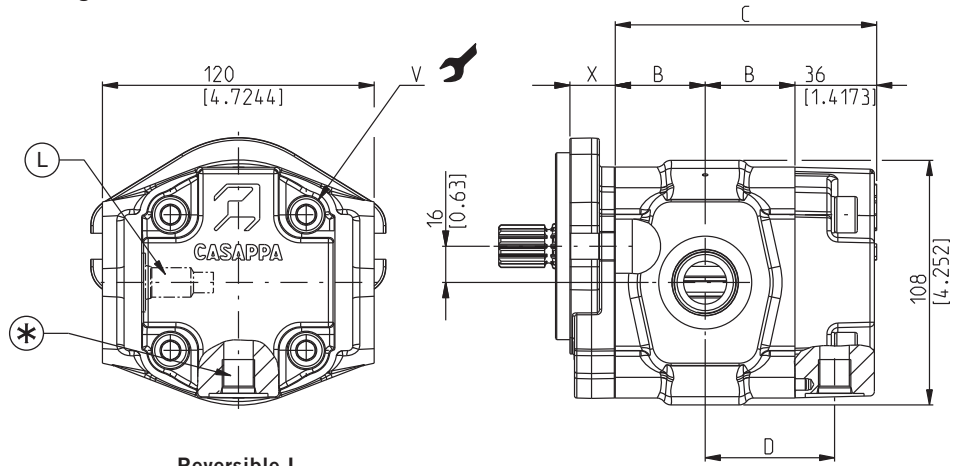

Reversible L

Mounting flange type (version 0)	X mm (inch)
E2	18 (0.7087)
B2	18,8 (0.7402)
B4	16 (0.6299)
B5	16 (0.6299)
B6	17,7 (0.6969)
S9	20 (0.7874)
WD	20 (0.7874)
S5	20 (0.7874)
W8	49,8 (1.9606)

Mounting flange and rear cover material	V Screws tightening torque Nm (lbf in)
Both or at least one in aluminium	45 ^{±4.5} (358 ÷ 438)
Both in cast iron	70 ^{±7} (558 ÷ 682)

REVERSIBLE L DRAIN PORT POSITION:

L = Side - * = Bottom

For single rotation S - D, reversible rotation R and B the rear cover is available in cast iron and aluminium. For reversible rotation L the rear cover is available in aluminium only.

Drive shafts: page 26 ÷ 28

Mounting flange: page 29 ÷ 33

Ports: page 34 ÷ 37

Pump type Motor type	A mm (inch)	B mm (inch)	C mm (inch)	D mm (inch)
PH. 20•19	96,4 (3.7952)	36,45 (1.4350)	107,9 (4.2480)	53,45 (2.1043)
PH. 20•20	99,5 (3.9173)	38 (1.4961)	111 (4.3701)	55,5 (2.1850)
PH. 20•23	102,8 (4.0472)	39,65 (1.5610)	114,3 (4.5000)	57,15 (2.2500)
PH. 20•24,5	105,1 (4.1378)	40,8 (1.6063)	116,6 (4.5905)	58,3 (2.2953)
PH. 20•25	107,5 (4.2323)	42 (1.6535)	119 (4.6850)	59,5 (2.3425)
PH. 20•27,8	110,2 (4.3386)	43,35 (1.7067)	121,7 (4.7913)	60,85 (2.3957)
PH. 20•31,5	117,5 (4.6260)	47 (1.8504)	129 (5.0787)	64,5 (2.5394)

Replaces: 01/06.2009

02/06.2010

PH 20

SINGLE UNITS REAR PORTS

Replaces: 01/06.2009

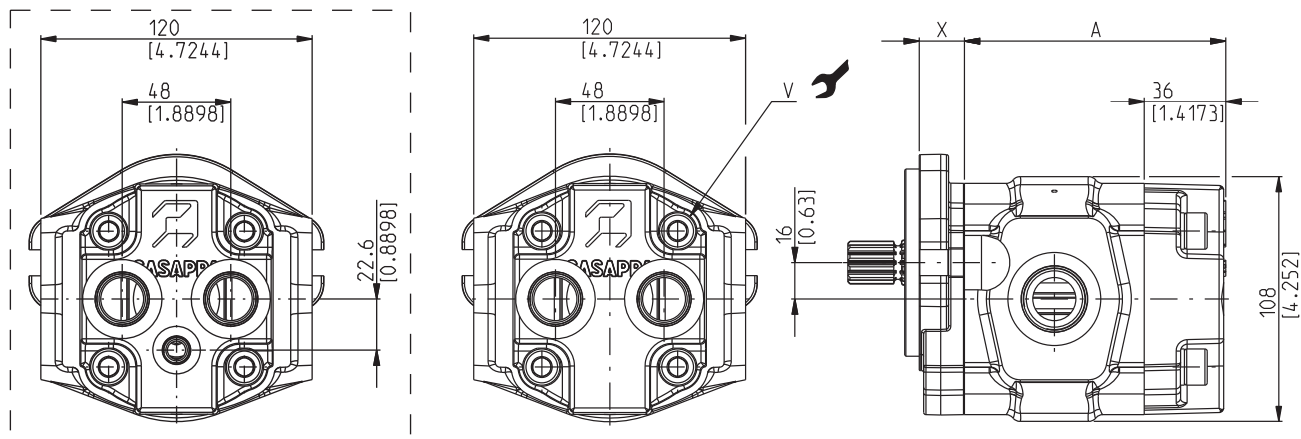

Reversible R

Single rotation S - D and Reversible B

DCAT034-005

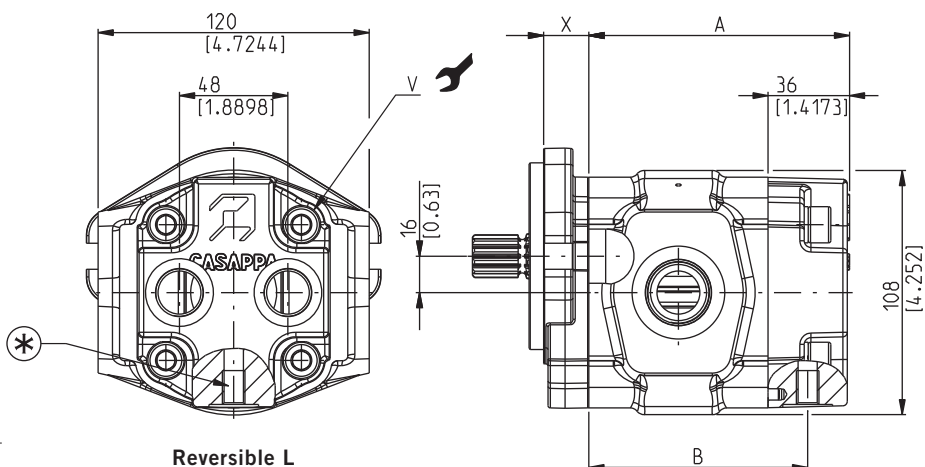

Reversible L

Mounting flange type (version 0)	X mm (inch)
E2	18 (0.7087)
B2	18,8 (0.7402)
B4	16 (0.6299)
B5	16 (0.6299)
B6	17,7 (0.6969)
S9	20 (0.7874)
WD	20 (0.7874)
S5	20 (0.7874)
W8	49,8 (1.9606)

Mounting flange and rear cover material	V Screws tightening torque Nm (lbf in)
Both in aluminium or mounting flange in cast iron	45 ±4,5 (358 ÷ 438)

REVERSIBLE L DRAIN PORT POSITION:

* = Bottom

The rear cover is available in aluminium only.

Drive shafts: page 26 ÷ 28

Mounting flange: page 29 ÷ 33

Ports: page 34 ÷ 37

02/06.2010

Pump type Motor type	A mm (inch)	B mm (inch)
PH. 20•19	107,9 (4.2480)	89,9 (3.5393)
PH. 20•20	111 (4.3701)	93,5 (3.6811)
PH. 20•23	114,3 (4.5000)	96,8 (3.8110)
PH. 20•24,5	116,6 (4.5905)	99,1 (3.9016)
PH. 20•25	119 (4.6850)	101,5 (3.9961)
PH. 20•27,8	121,7 (4.7913)	104,2 (4.1024)
PH. 20•31,5	129 (5.0787)	111,5 (4.3898)

MULTIPLE PUMPS

POLARIS series pumps can be coupled together in combination. Where the input power requirements of each section varies, that with the greater requirement must be at the drive shaft end, and progressively smaller to the rear.

Features and performances are the same as the corresponding single pumps, but pressures must be limited by the transmissible torque of the drive and connecting shafts. To have appropriate data, use the formula below.

The maximum rotational speed is that of the lowest rated speed of the single units incorporated.

Available with common inlet and separated stages. For more information please consult our technical sales department.

M	lbf in (Nm)	Torque
V	in ³ /rev (cm ³ /rev)	Displacement
Δp	psi (bar)	Pressure
$\eta_m = \eta_m (V, \Delta p, n)$	(≈ 0,88)	Mechanical efficiency

$$M = \frac{\Delta p \text{ (bar)} \cdot V \text{ (cm}^3\text{/rev)}}{62,83 \cdot \eta_m} \quad \text{[Nm]}$$

DRIVE SHAFT SELECTION

The torque absorbed from the shaft of the first pump results from the sum of the torques due to all single stages. The achieved value must not exceed the maximum torque limit given for the shaft of the first pump. Diagrams providing approximate selection data will be found on page 15.

Example

Let us consider a double pump PHP20•19 + PLP20•4. If we suppose that we have to work with the first pump at a pressure of 2900 psi (200 bar) and the second pump at a pressure of 2175 psi (150 bar), the graph 1 shows that the torque absorbed by PHP20•19 is 611 lbf in (69 Nm) and the graph 2 shows that the torque absorbed by PLP20•4 is 115 lbf in (13 Nm) [acceptable value because it doesn't exceed the maximum connecting shaft torque that is 974 lbf in (110 Nm), see page 17]. The torque to be transmitted by the first drive shaft will thus be 611+115= 726 lbf in (69+13= 82 Nm), this value must not exceed the shaft's maximum rated value.

01/06.2009

MULTIPLE PUMPS

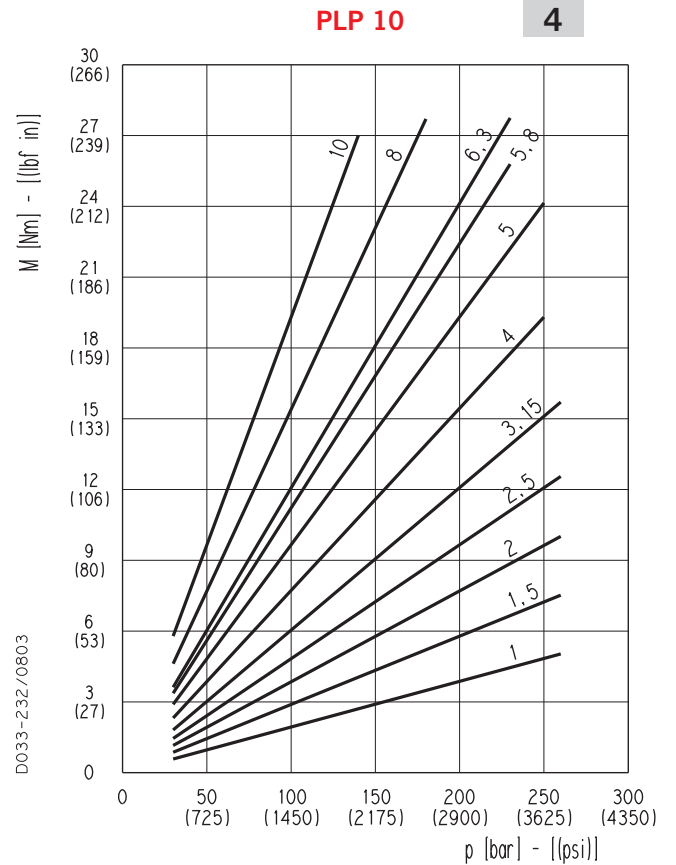
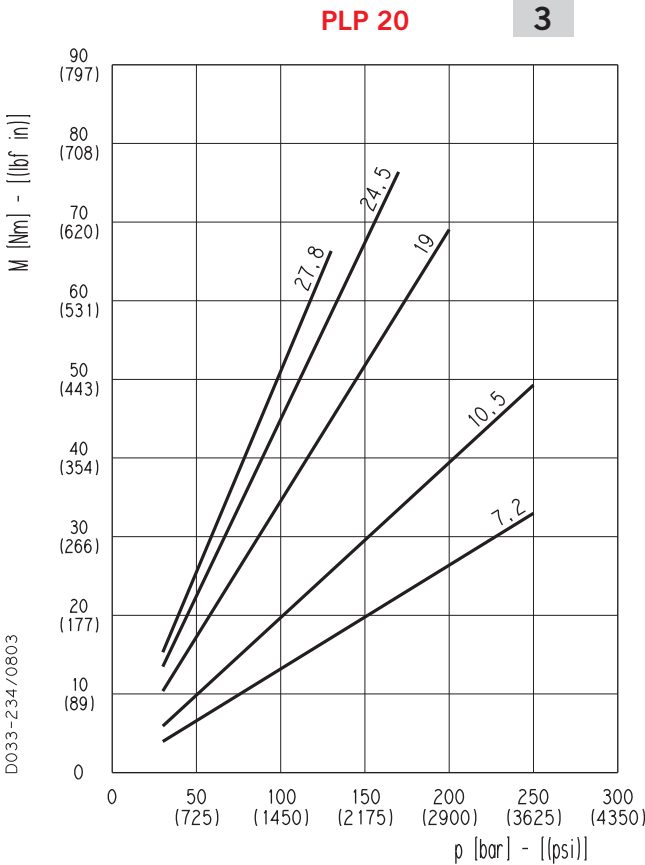
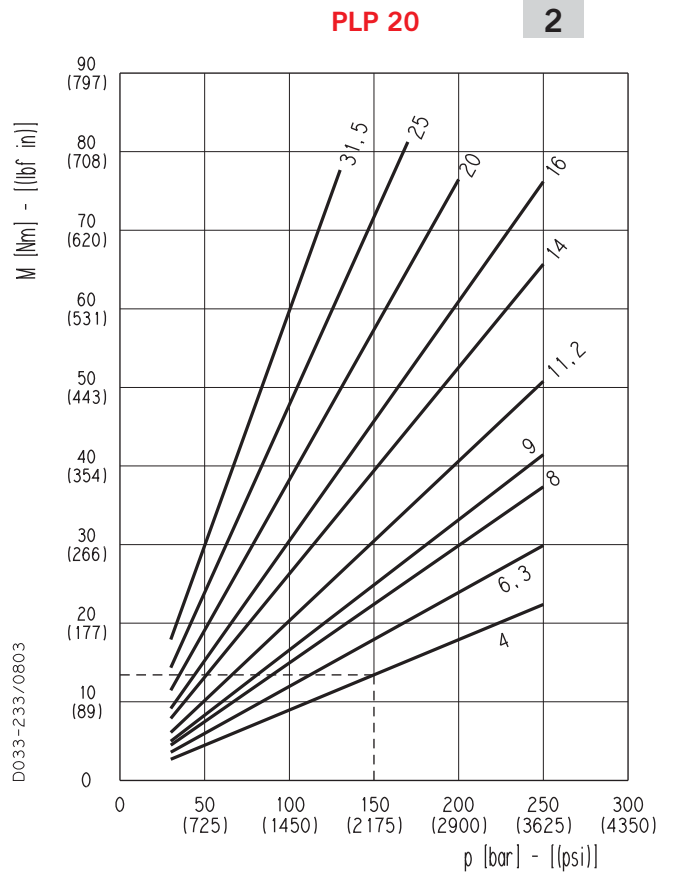
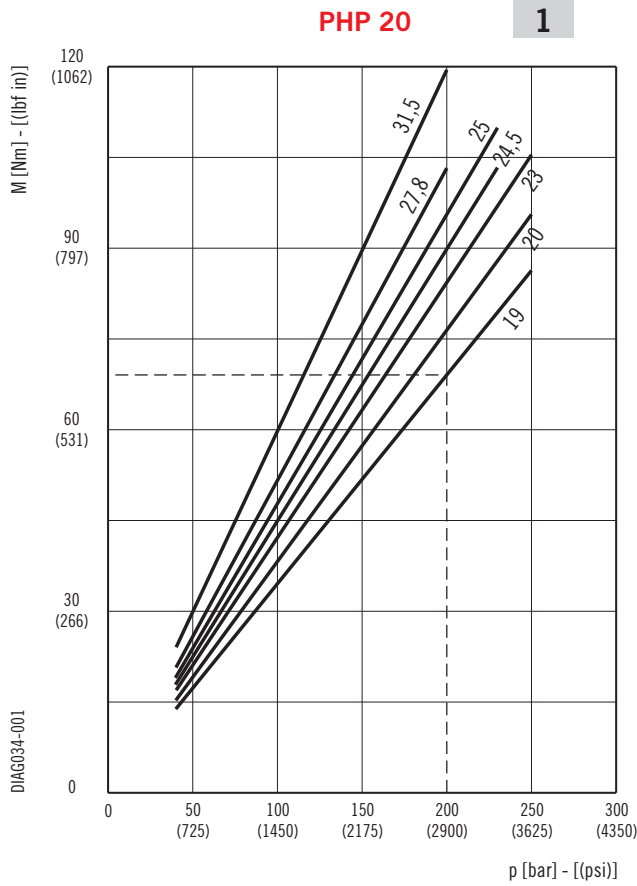

01/06.2009

COMMON INLET - PORTS POSITION

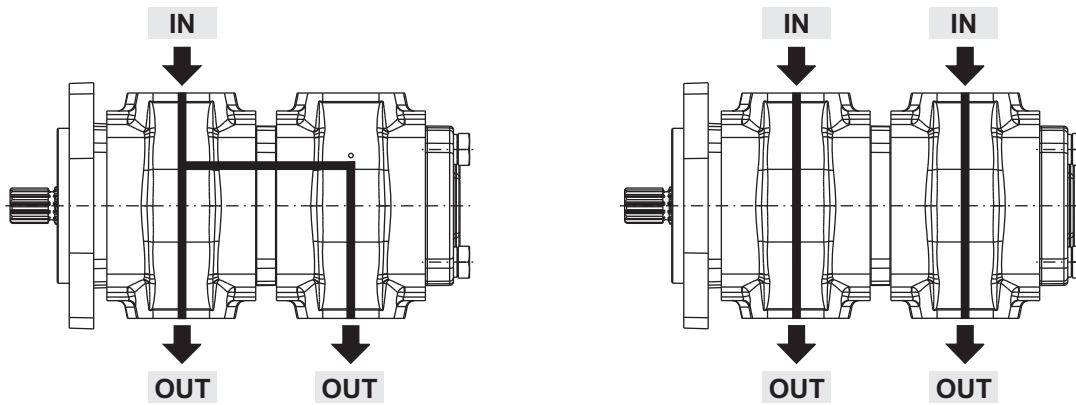

Reduced inlets provide overall systems savings by reducing the cost of redundant inlet hose and fittings. For other combinations please consult our sales department.

MULTIPLE PUMPS COMBINATION

PHP 20/20	STANDARD VERSION	S6
PHP 20/20	COMMON INLET VERSION	S7

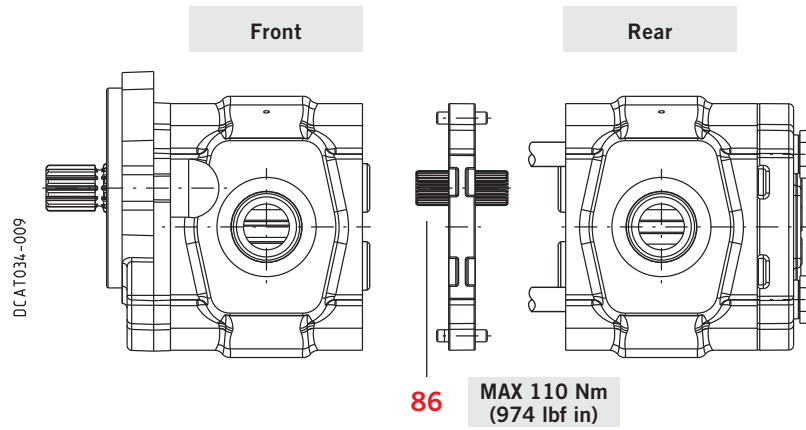

PHP 20/20	SEPARATED STAGES VERSION	Z6
-----------	--------------------------	-----------

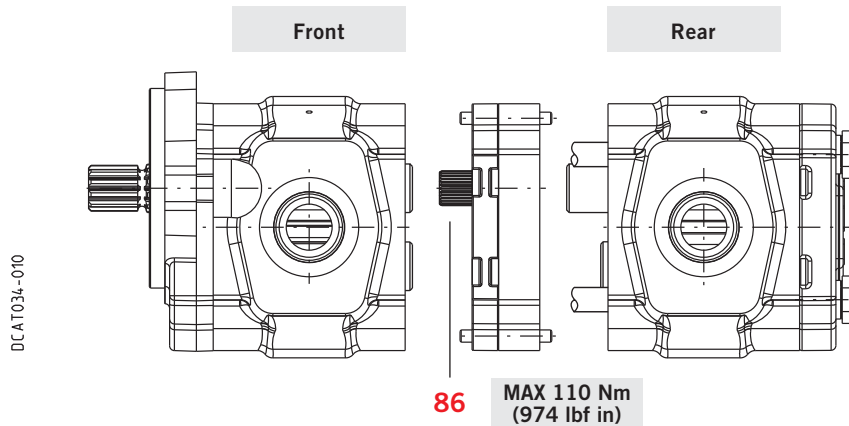

01/06.2009

MULTIPLE PUMPS COMBINATION

PHP20 / PLP20	STANDARD VERSION	S6
PHP20 / PLP20	COMMON INLET VERSION	S7

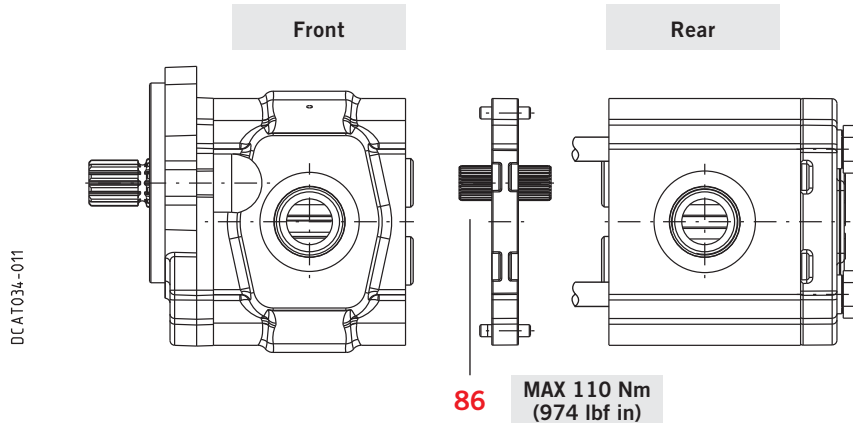

PHP20 / PLP20	SEPARATED STAGES VERSION	Z6
---------------	--------------------------	-----------

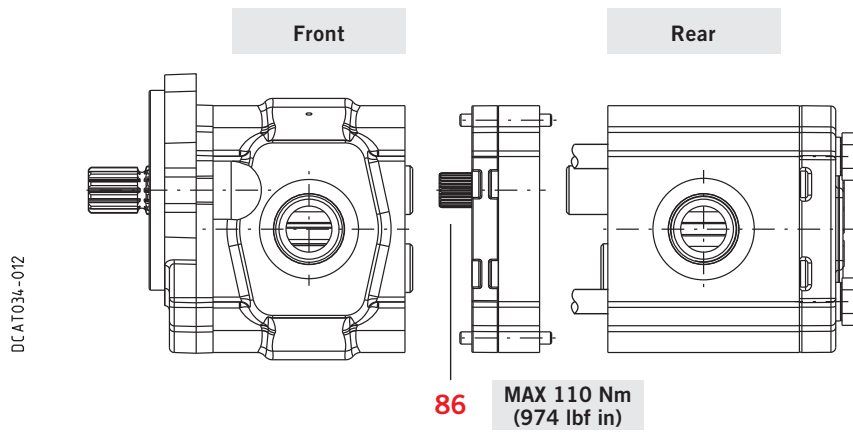

PHP20 / PLP10	STANDARD VERSION	T6
PHP20 / PLP10	COMMON INLET VERSION	T7

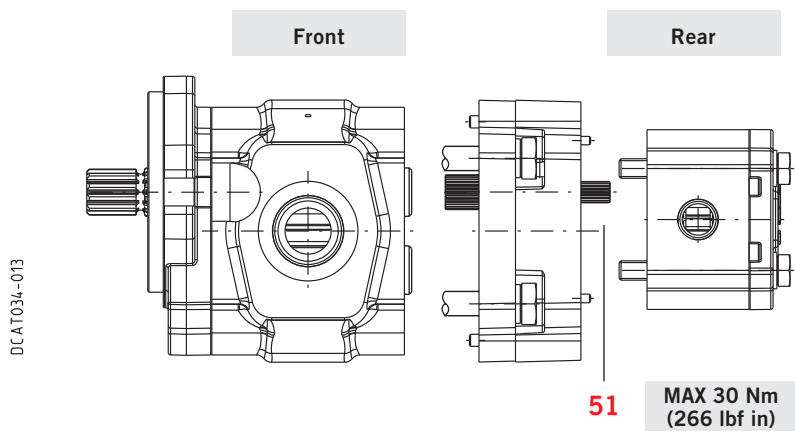

01/06.2009

MULTIPLE PUMPS COMBINATION

PHP20 / PLP10

SEPARATED STAGES VERSION

Z6

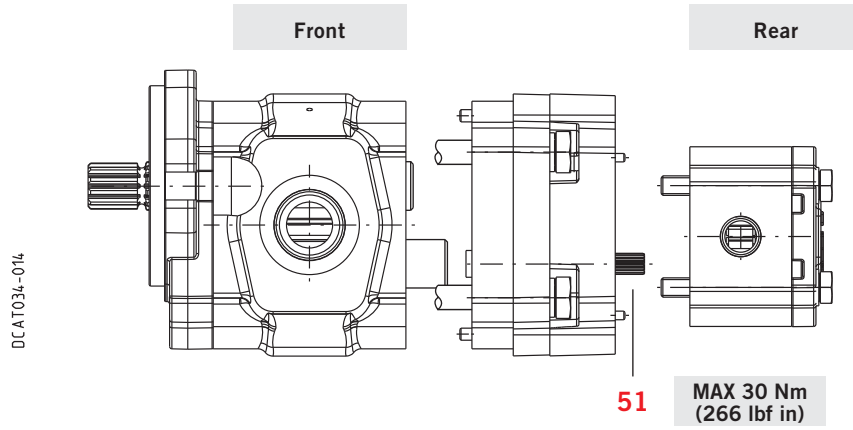

01/06.2009

PH 20

MULTIPLE PUMPS

PHP 20/20

Mounting flange is available in cast iron only.

Replaces: 01/06.2009

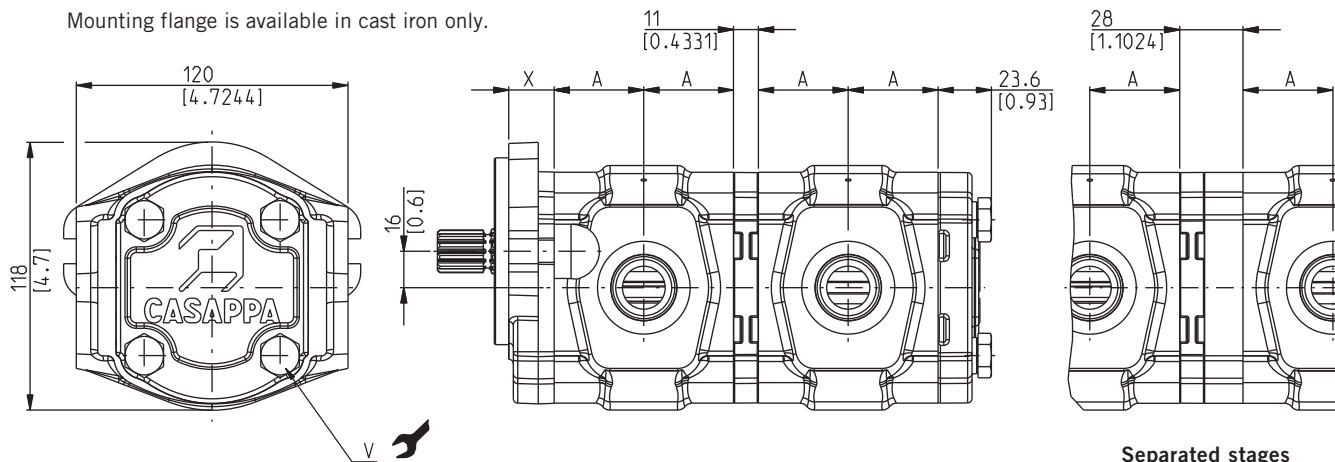

Separated stages

PHP 20/PLP 20

DCAT034-015

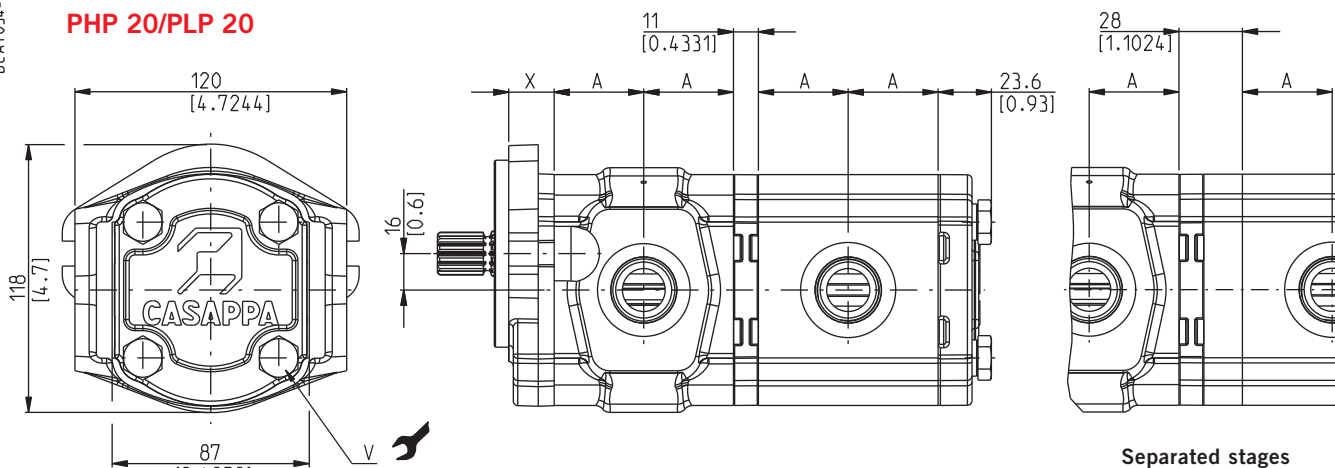

Separated stages

Mounting flange and rear cover material	V
	Screws tightening torque Nm (lbf in)
Both or at least one in aluminium	45 ±4,5 (358 ÷ 438)
Both in cast iron	70 ±7 (558 ÷ 682)

Pump type	A
	mm (inch)
PHP 20•19	36,45 (1.4350)
PHP 20•20	38 (1.4961)
PHP 20•23	39,65 (1.5610)
PHP 20•24,5	40,8 (1.6063)
PHP 20•25	42 (1.6535)
PHP 20•27,8	43,35 (1.7067)
PHP 20•31,5	47 (1.8504)

Pump type	A
	mm (inch)
PLP 20•4	25,75 (1.0138)
PLP 20•6,3	27 (1.0630)
PLP 20•7,2	27,5 (1.0826)
PLP 20•8	28,25 (1.1122)
PLP 20•9	28,9 (1.1378)
PLP 20•10,5	30,25 (1.1909)
PLP 20•11,2	30,5 (1.2008)
PLP 20•14	33 (1.2992)
PLP 20•16	34,75 (1.3681)
PLP 20•19	36,45 (1.4350)
PLP 20•20	38 (1.4961)
PLP 20•24,5	40,8 (1.6063)
PLP 20•25	42 (1.6535)
PLP 20•27,8	43,35 (1.7067)
PLP 20•31,5	47 (1.8504)

The rear cover is available in cast iron and aluminium.

Drive shafts: page 26 ÷ 28
Mounting flange: page 29 ÷ 33
Ports: page 34 ÷ 37

Mounting flange type (version 0)	X
	mm (inch)
E2	18 (0.7087)
B2	18,8 (0.7402)
B4	16 (0.6299)
B5	16 (0.6299)
B6	17,7 (0.6969)
S9	20 (0.7874)
WD	20 (0.7874)
S5	20 (0.7874)
W8	○ 49,8 (1.9606)

02/06.2010

PH 20

MULTIPLE PUMPS

PHP 20/PLP 10

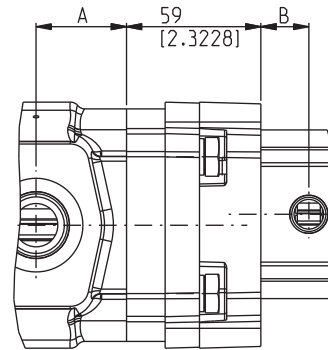
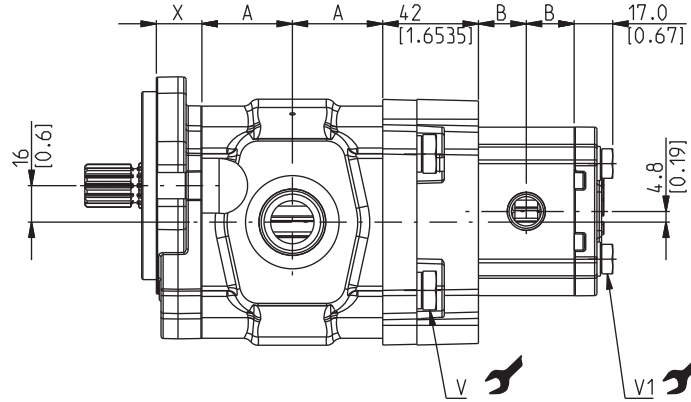
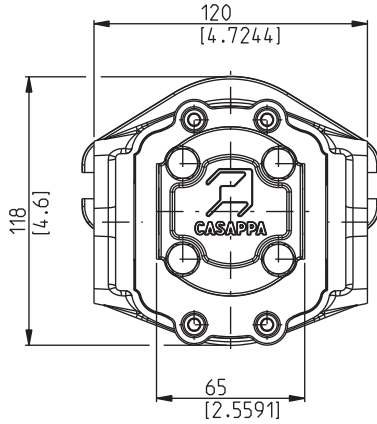

Separated stages

DCAT034-019

Replaces: 01/06.2009

Mounting flange and rear cover material	V Screws tightening torque Nm (lbf in)	V1
Both in aluminium or at least one in cast iron	45 $\pm 4,5$ (358 \div 438)	25 $\pm 2,5$ (199 \div 243)
Both in cast iron	70 ± 7 (558 \div 682)	–

The rear cover is available in cast iron and aluminium.

Drive shafts: page 26 \div 28
Mounting flange: page 29 \div 33
Ports: page 34 \div 37

Pump type	A mm (inch)
PHP 20•19	36,45 (1.4350)
PHP 20•20	38 (1.4961)
PHP 20•23	39,65 (1.5610)
PHP 20•24,5	40,8 (1.6063)
PHP 20•25	42 (1.6535)
PHP 20•27,8	43,35 (1.7067)
PHP 20•31,5	47 (1.8504)

Pump type	B mm (inch)
PLP 10•1	17,6 (0.6929)
PLP 10•1,5	18,4 (0.7244)
PLP 10•2	19,2 (0.7559)
PLP 10•2,5	20 (0.7874)
PLP 10•3,15	21 (0.8268)
PLP 10•4	22,4 (0.8819)
PLP 10•5	24 (0.9449)
PLP 10•5,8	25,3 (0.9961)
PLP 10•6,3	26 (1.0236)
PLP 10•8	28,75 (1.1319)
PLP 10•10	32 (1.2598)

Mounting flange type (version 0)	X mm (inch)
E2	18 (0.7087)
B2	18,8 (0.7402)
B4	16 (0.6299)
B5	16 (0.6299)
B6	17,7 (0.6969)
S9	20 (0.7874)
WD	20 (0.7874)
S5	20 (0.7874)
W8	49,8 (1.9606)

02/06.2010

VERSIONS

For each version, the possible combination between drive shafts and mounting flanges are shown on pages 29 ÷ 33.
 For the outboard bearing life expectancy, diagrams providing approximate selection data will be found on subsequent pages.
 For particular applications please consult our technical sales department.

VERSION 0

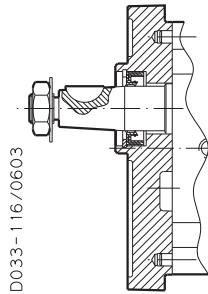

Version for applications without radial and axial load on the drive shaft.

VERSION W8

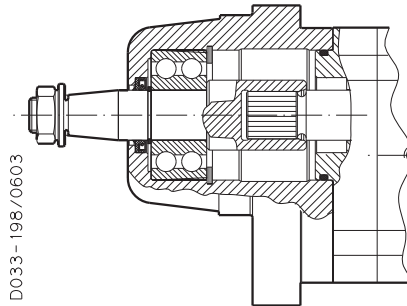

VERSION 4

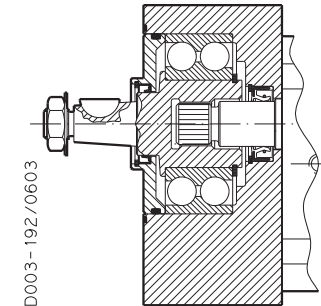

VERSION 5

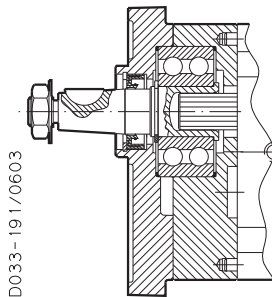

VERSION 6

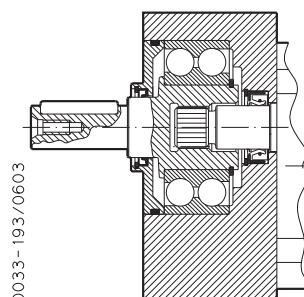

VERSION 7

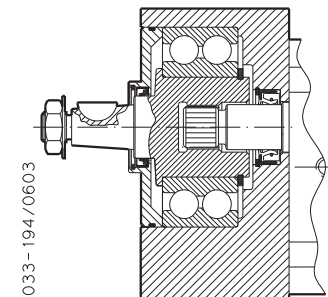

VERSION 8

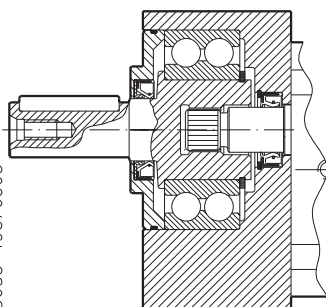

VERSION 9

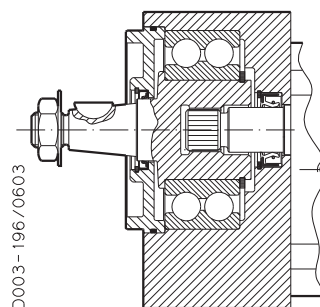

01/06.2009

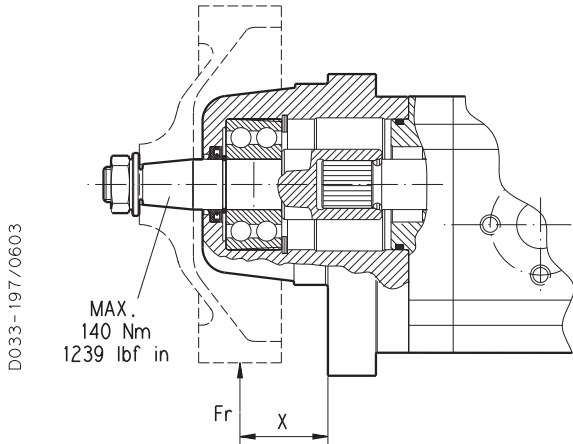

X= Distance of the radial load result from the mounting flange [mm (in)].

Each curve has been obtained at:
Lubricant oil ISO VG 46
Temperature 60 °C (140 °F)
Without or with very low axial load

Example

Fr Radial load	1915 N (430.88 lbf)
X	20 mm (0.7874 in)
Speed	2000 min ⁻¹
Rating fatigue life	≈ 2000 h

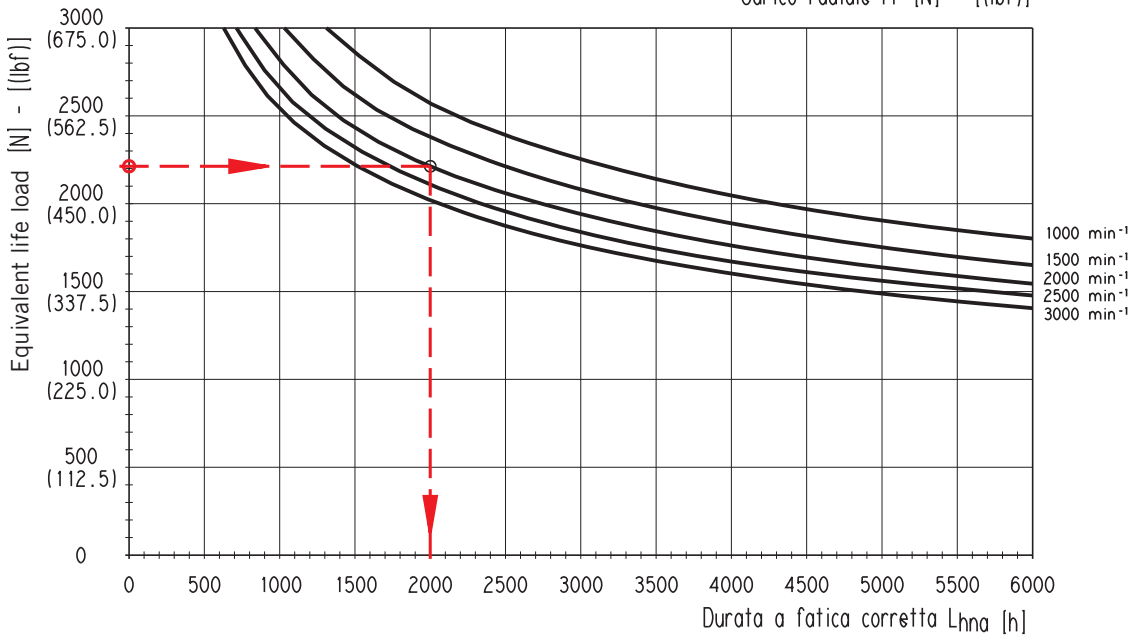
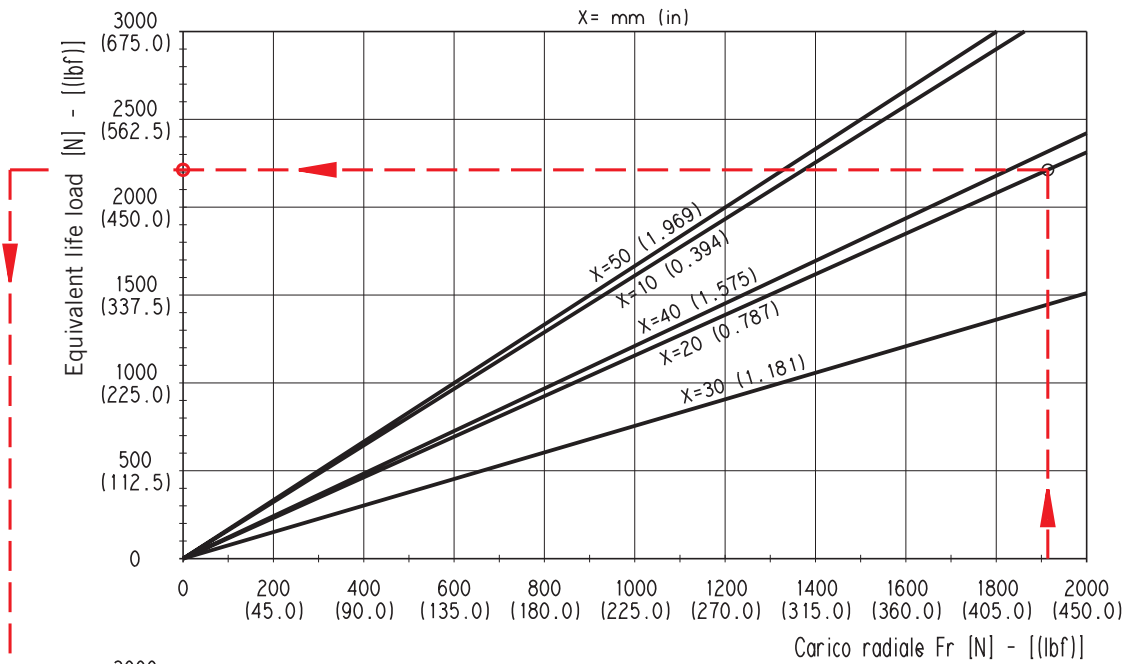

D033-124/0606

01/06.2009

D003-114/0603

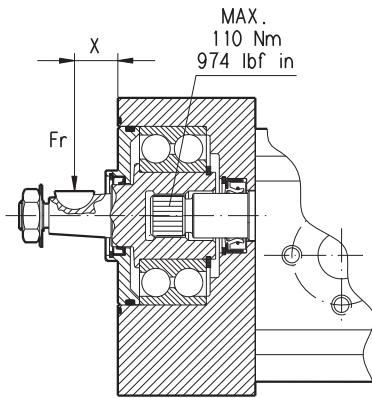

X = Distance of the radial load result from the mounting flange [mm (in)].

Each curve has been obtained at:
Lubricant oil ISO VG 46
Temperature 60 °C (140 °F)
Without or with very low axial load

Example

Fr Radial load	1850 N (416.25 lbf)
X	20 mm (0.7874 in)
Speed	2000 min ⁻¹
Rating fatigue life	≈ 2000 h

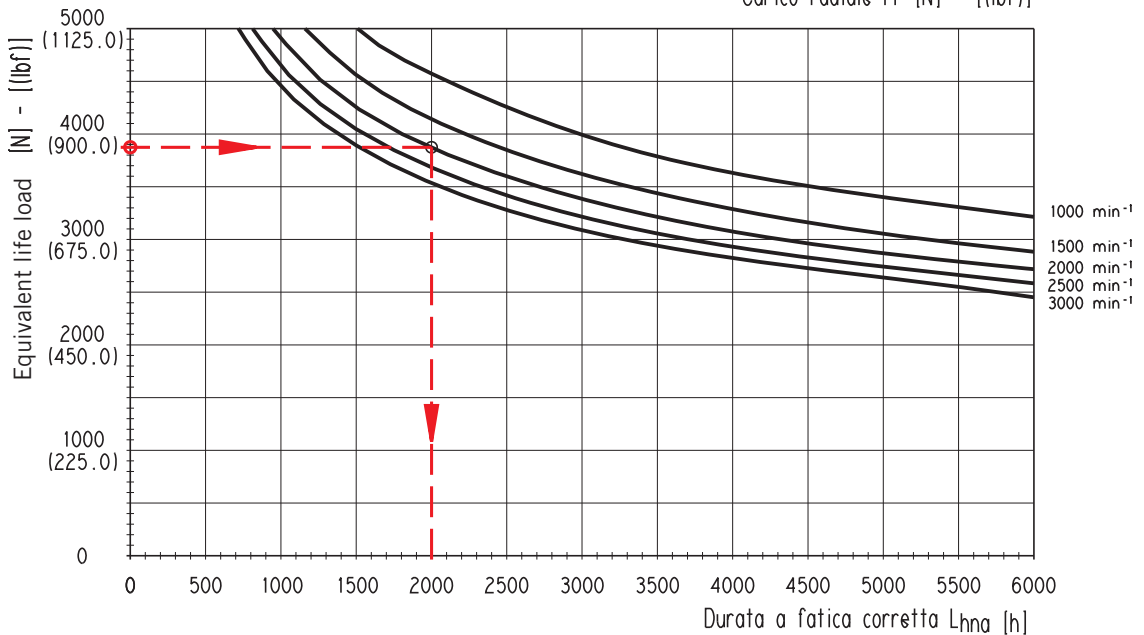
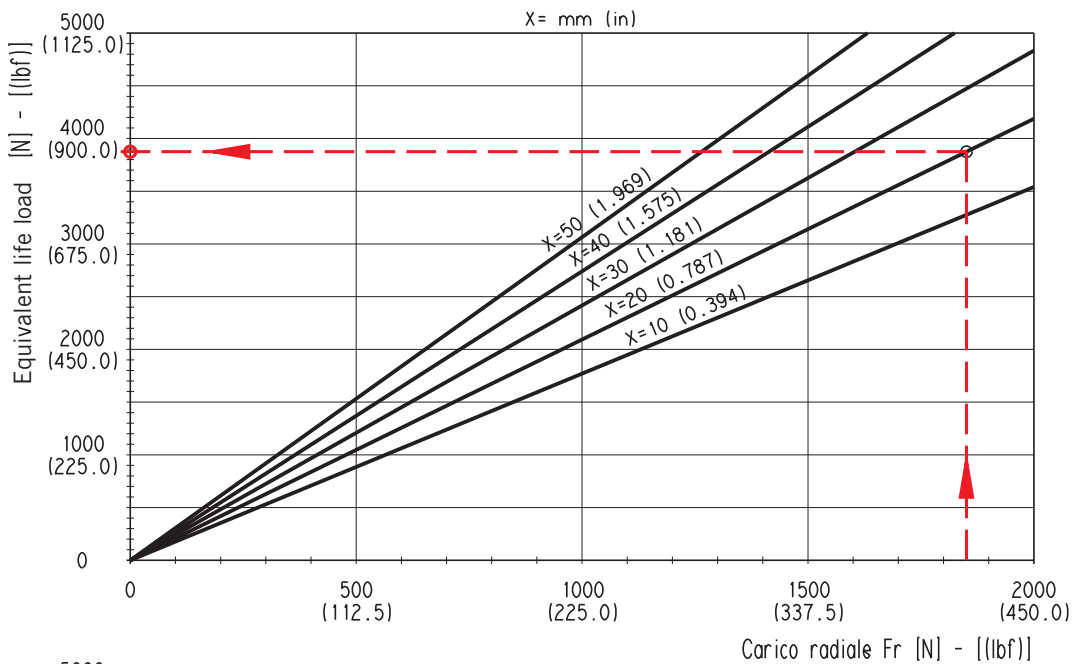

01/06.2009

D033-122/0606

D033-1115/0603

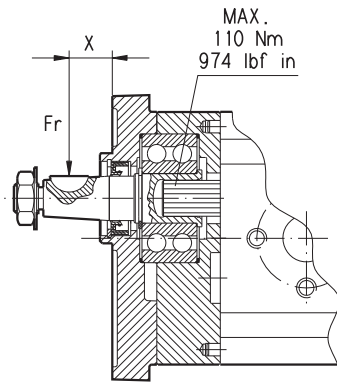

X= Distance of the radial load result from the mounting flange [mm (in)].

Each curve has been obtained at:
Lubricant oil ISO VG 46
Temperature 60 °C (140 °F)
Without or with very low axial load

Example

Fr Radial load	800 N (180 lbf)
X	20 mm (0.7874 in)
Speed	2000 min ⁻¹
Rating fatigue life	≈ 2000 h

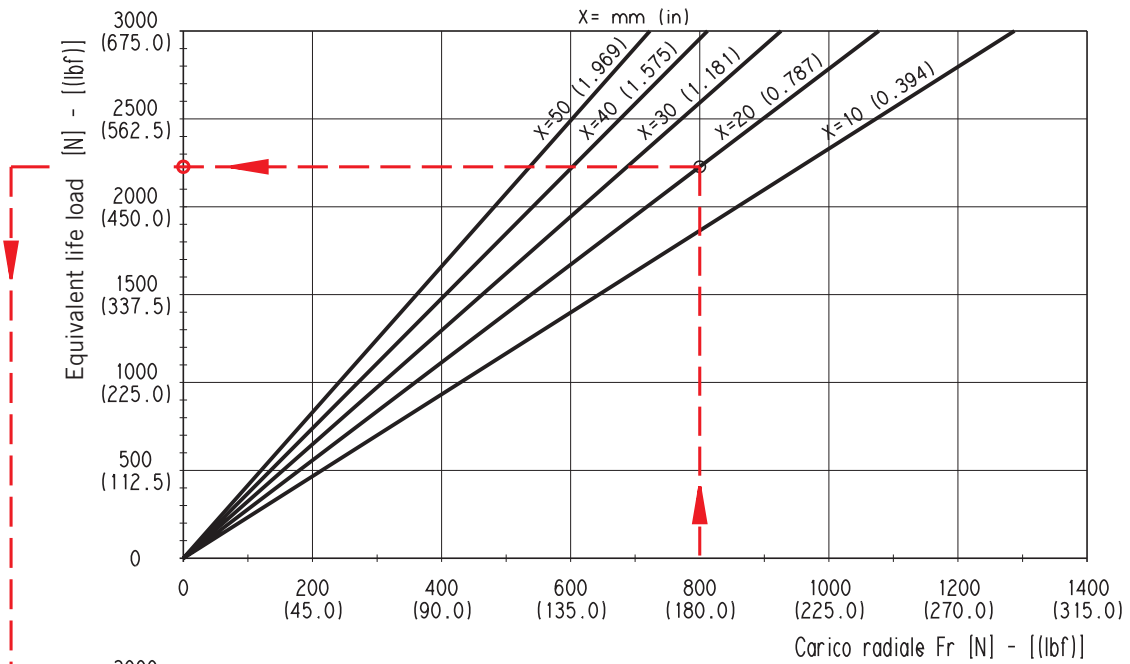

D033-121/0606

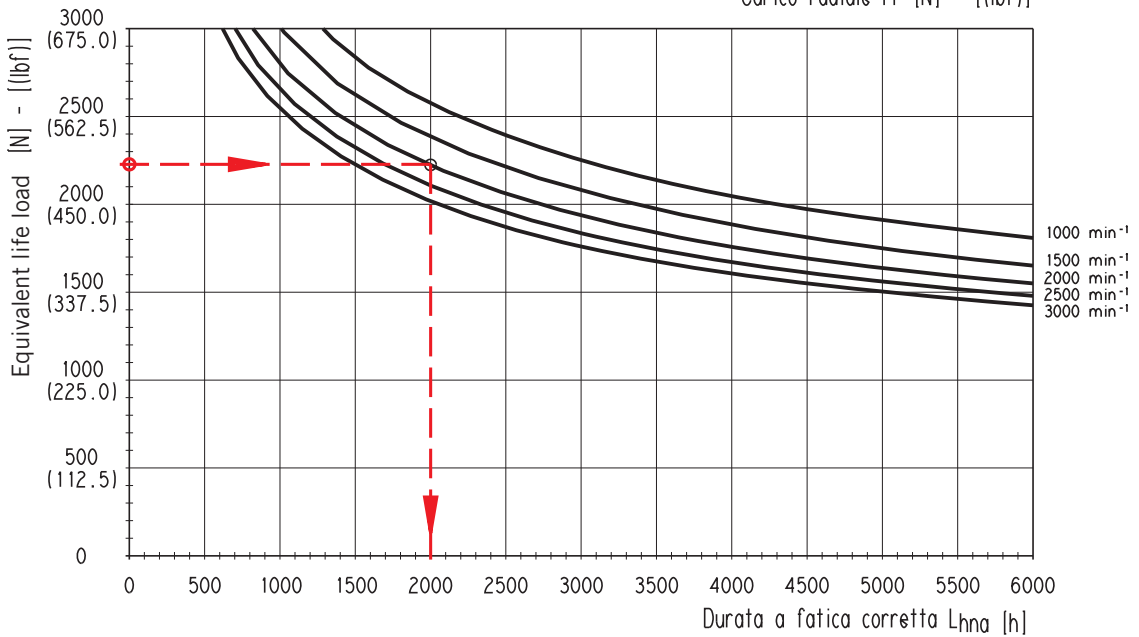

01/06.2009

D033-118/0603

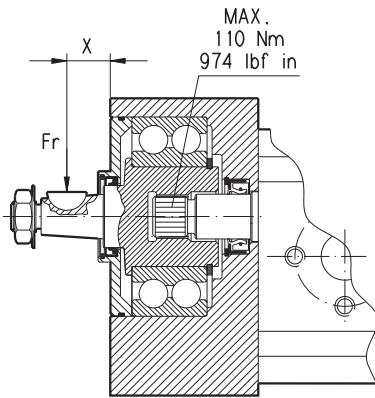

X= Distance of the radial load result from the mounting flange [mm (in)].

Each curve has been obtained at:
Lubricant oil ISO VG 46
Temperature 60 °C (140 °F)
Without or with very low axial load

Example

Fr Radial load	1858 N (524.25 lbf)
X	20 mm (0.787 in)
Speed	2000 min ⁻¹
Rating fatigue life	≈ 2000 h

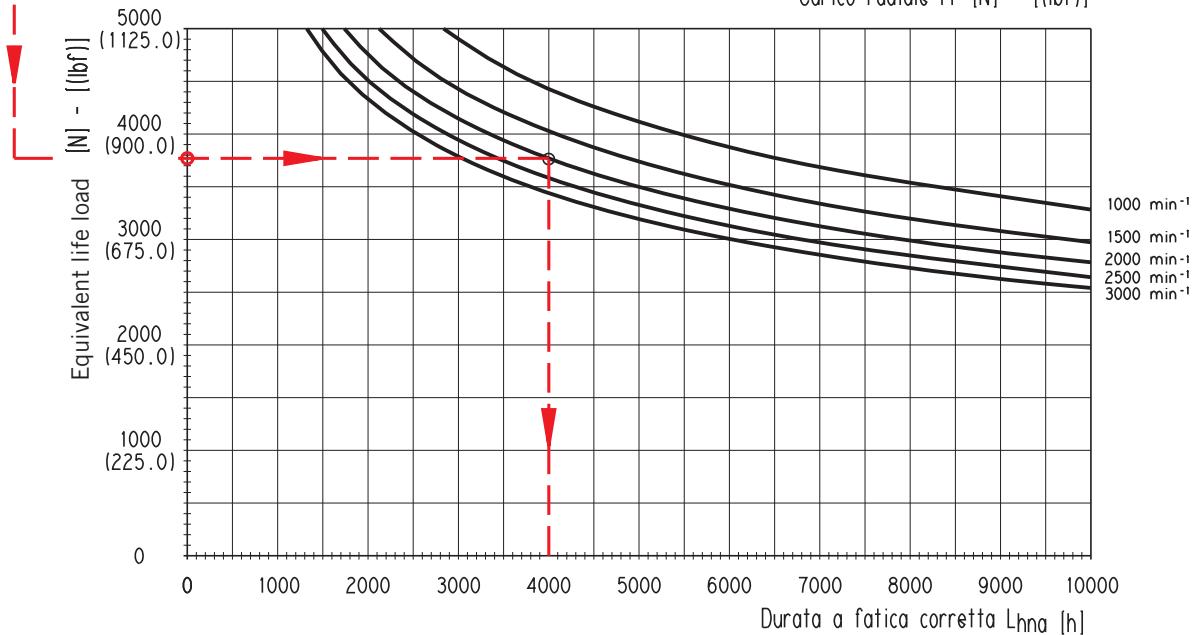
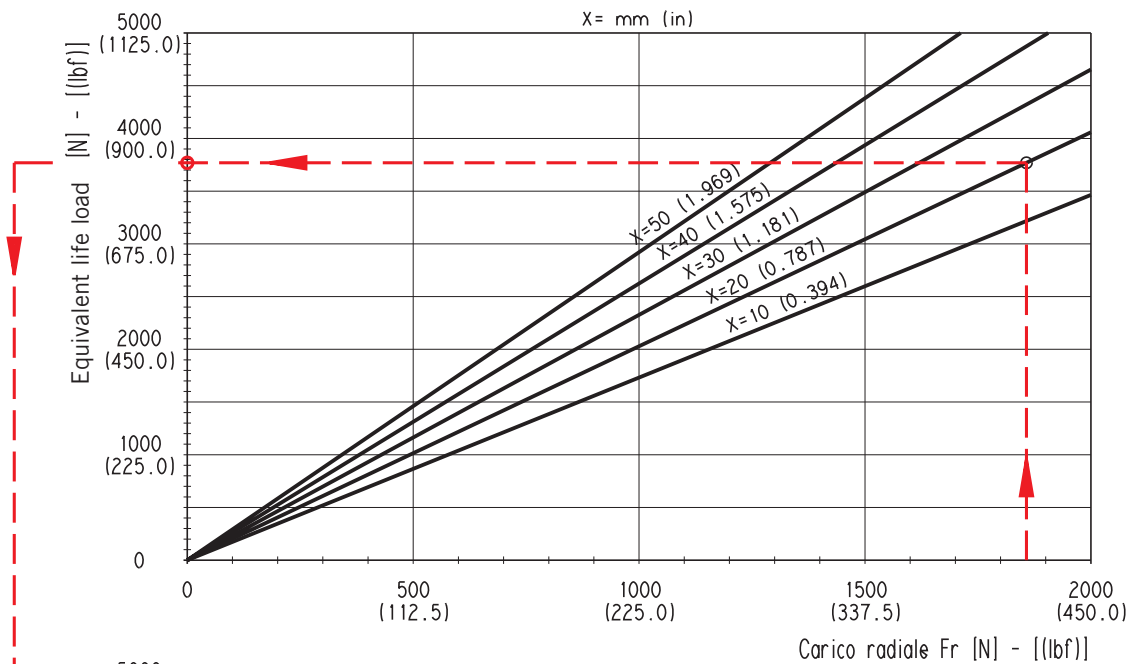

01/06.2009

D033-123/0606

DRIVE SHAFTS

EUROPEAN TAPERED 1:8

82

Not available with size:

○ **20•23 - 20•24,5 - 20•27,8**

Mounting face refer to flange code **E2**

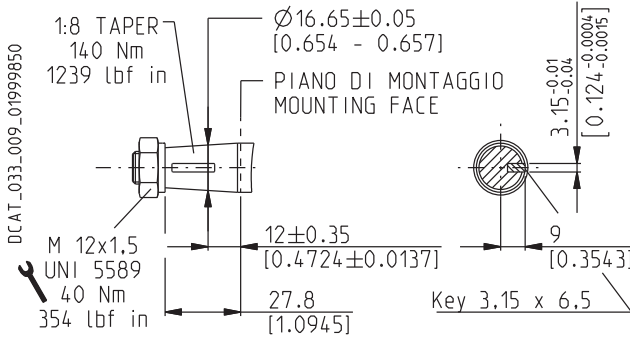

GERMAN TAPERED 1:5

54

Not available with size:

○ **20•19 - 20•24,5 - 20•27,8 - 20•31,5**

Mounting face refer to flange code **B2**

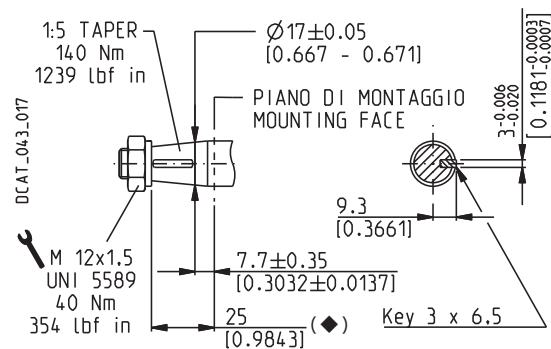

(◆) 27.5 [1.0827] with flanges code **B4** and **B5**

GERMAN TAPERED 1:5

55

Only for version **5**, **9** and **W8** with outboard bearing

Mounting face refer to flange code **B2**

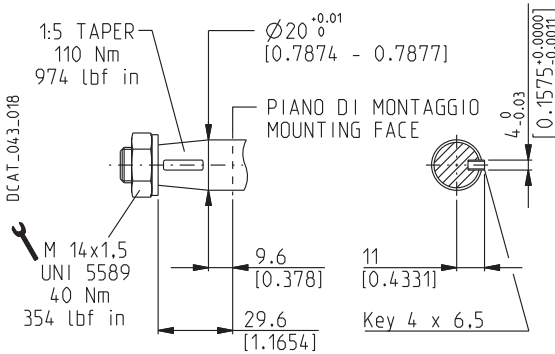

STRAIGHT

46

Not available with size:

○ **20•19 - 20•24,5 - 20•25 - 20•27,8 - 20•31,5**

Mounting face refer to flange code **E2**

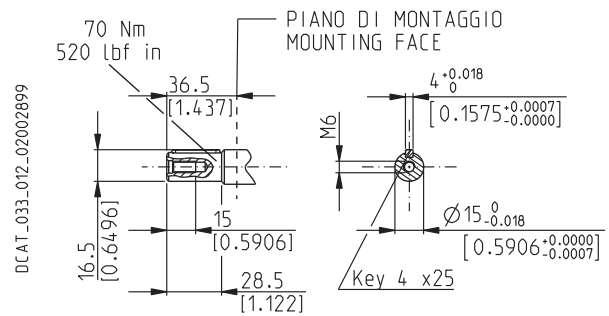

SAE "A" SPLINE

03

Not available with size:

○ **20•24,5 - 20•27,8**

Mounting face refer to flange code **S9**

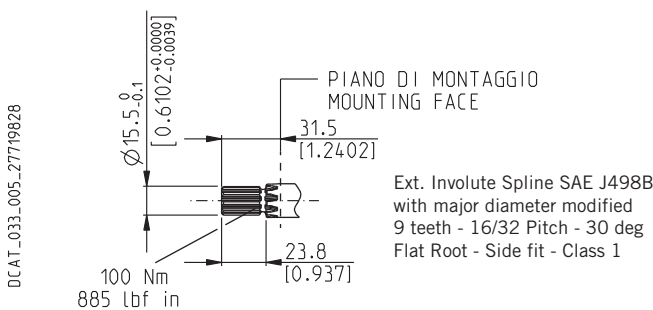

Ext. Involute Spline SAE J498B with major diameter modified 9 teeth - 16/32 Pitch - 30 deg Flat Root - Side fit - Class 1

SPLINE

01

Not available with size:

○ **20•19**

Mounting face refer to flange code **S9**

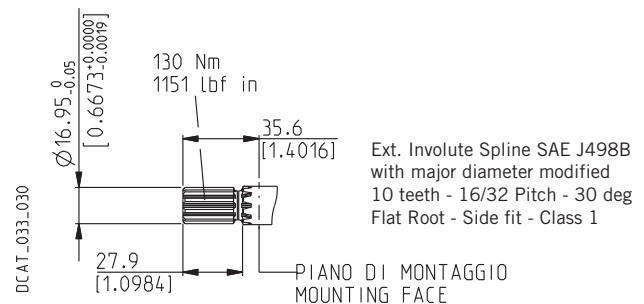

Ext. Involute Spline SAE J498B with major diameter modified 10 teeth - 16/32 Pitch - 30 deg Flat Root - Side fit - Class 1

Replaces: 01/06.2009

○ 02/06.2010

DRIVE SHAFTS

SAE SPLINE

07

Not available with size:

20•19 - 20•24,5 - 20•27,8

Mounting face refer to flange code **S9**

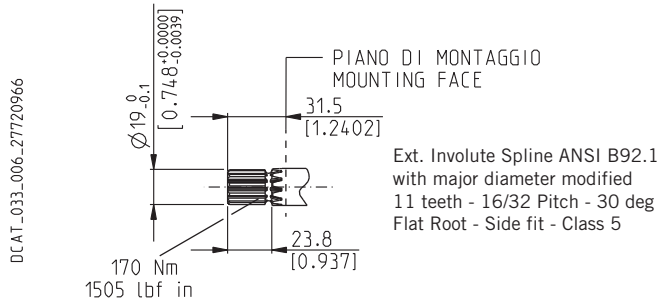

SAE "A" STRAIGHT

31

Not available with size:

20•19 - 20•24,5 - 20•27,8

Mounting face refer to flange code **S9**

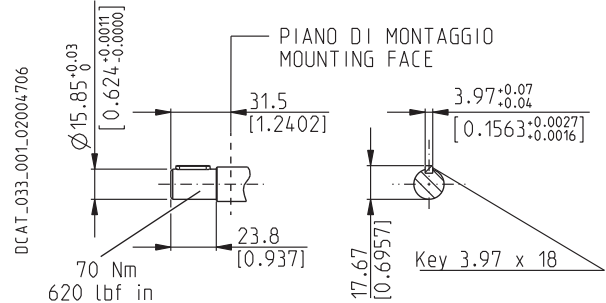

STRAIGHT

49

Not available with size:

20•19 - 20•24,5

Mounting face refer to flange code **S9**

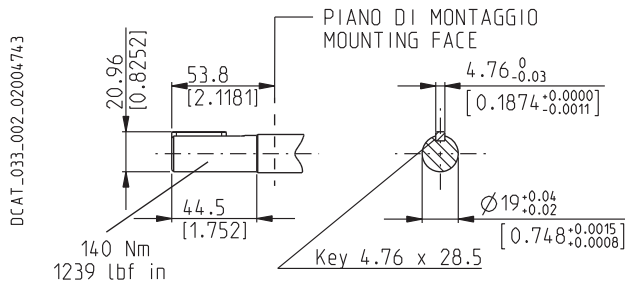

STRAIGHT

50

Not available with size:

20•19 - 20•24,5 - 20•27,8

Mounting face refer to flange code **S9**

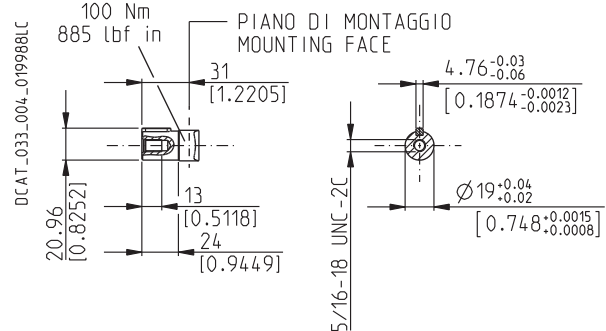

SAE "B" SPLINE

04

Not available with size:

20•24,5 - 20•27,8

Mounting face refer to flange code **S5**

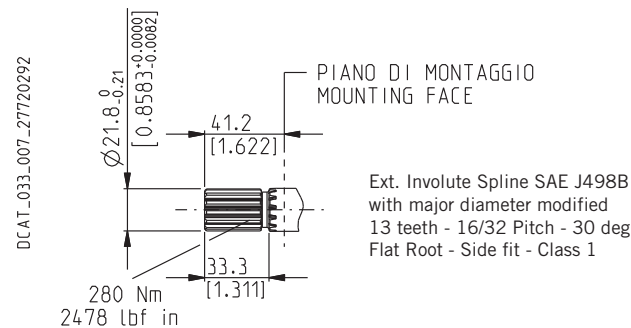

SAE "B" STRAIGHT

32

Not available with size:

20•19 - 20•24,5 - 20•27,8

Mounting face refer to flange code **S5**

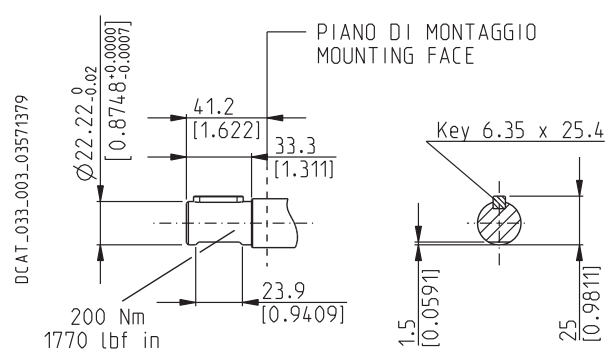

01/06.2009

DRIVE SHAFTS

DIN 5482 SPLINE

12

Not available with size:

20•19 - 20•24,5 - 20•27,8

Mounting face refer to flange code **B2**

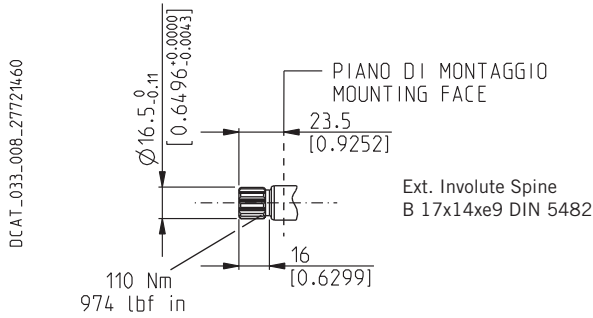

STRAIGHT

48

Only for version **6** with outboard bearing

Available in 0 version only with size:

20•20

Mounting face refer to flange code **E2**

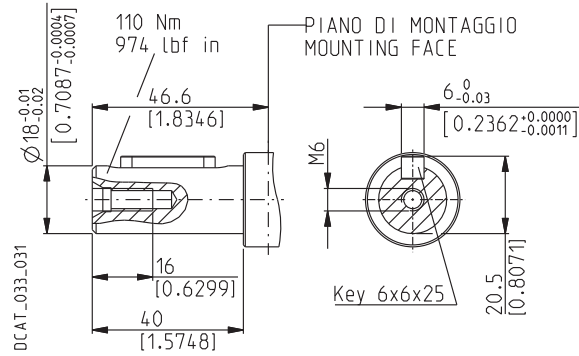

STRAIGHT

B1

Only for version **8** and **5** with outboard bearing

Mounting face refer to flange code **E2**

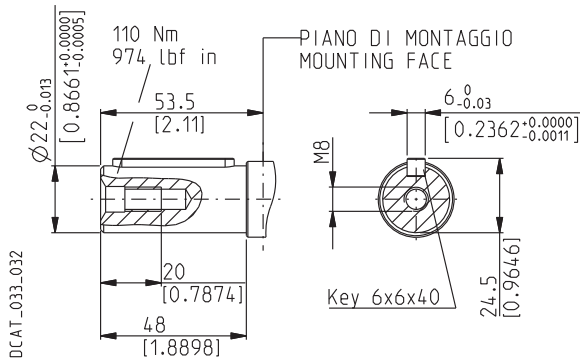

TANG

95

Not available with size:

20•19 - 20•24,5 - 20•27,8

Mounting face refer to flange code **B6**

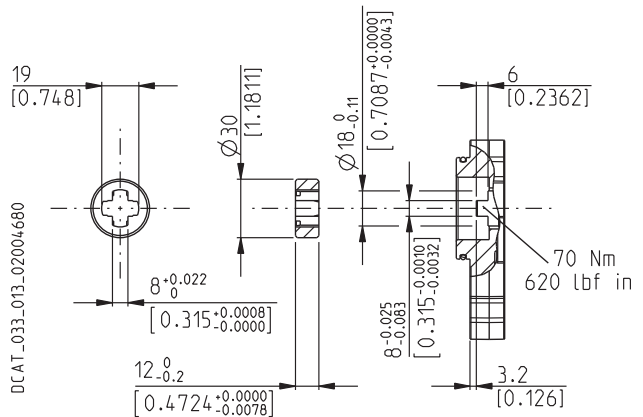

MOUNTING FLANGES AND TABLE OF COMPATIBILITY

EUROPEAN

E2

Material: cast iron and aluminium

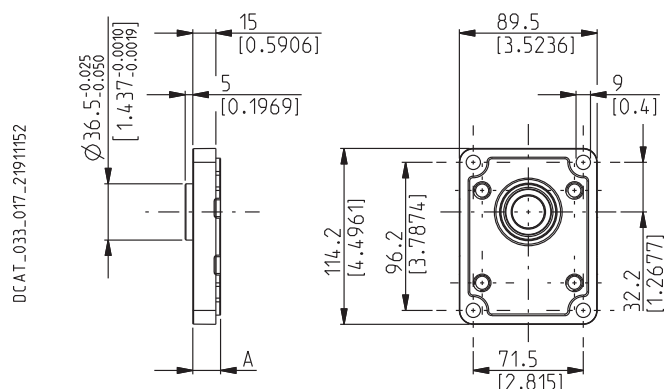

DRIVE SHAFTS

See page 26 ÷ 28

VERSIONS See page 21	A mm (in)	82	46	B1	03	04	07	12	31	48	49	50	54
0	18 (0.7087)	#	#		x	x	x	x	x	x	x	x	x
4	55,4 (2.1811)	#											
5	43,6 (1.7165)	#		x	x						x	x	x
6	55,4 (2.1811)									#			
7	59,4 (2.3386)	#											
8	59,4 (2.3386)			#									

Standard combination

x Available combination

GERMAN

B2

Material: cast iron and aluminium

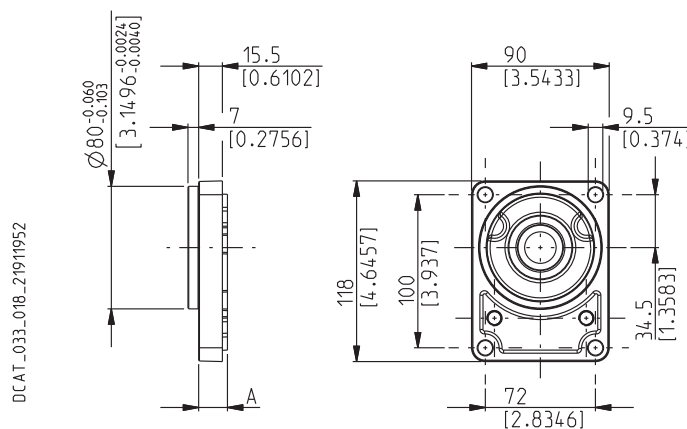

DRIVE SHAFTS

See page 26 ÷ 28

VERSIONS See page 21	A mm (in)	12	54	55	01	03	31	46	49	82
0	18,8 (0.7402)	#	#		x	x	x	x	x	x
5	44,4 (1.7480)		x	x		x			x	x
9	59,4 (1.7441)			x						

Standard combination

x Available combination

01/06.2009

MOUNTING FLANGES AND TABLE OF COMPATIBILITY

GERMAN 2 BOLTS B4

Material: cast iron and aluminium

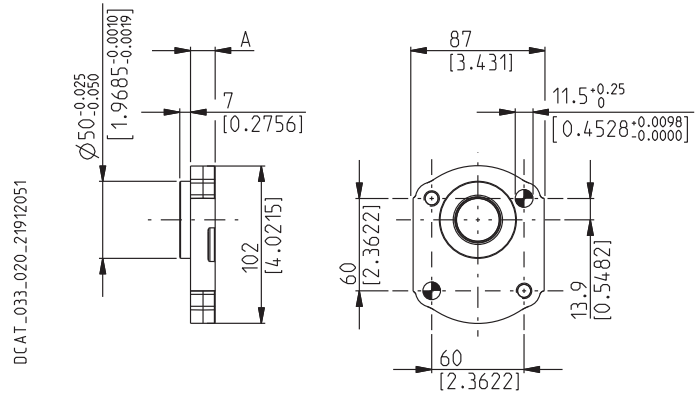

DRIVE SHAFTS
See page 26 ÷ 28

VERSIONS See page 21	A mm (in)	54	03	12	31	49	54	82
0	16 (0.63)	#	x	x	x	x	x	x
5	41,6 (1.6378)	x	x			x	x	x

Standard combination
x Available combination

GERMAN 2 BOLTS B5

Material: cast iron and aluminium

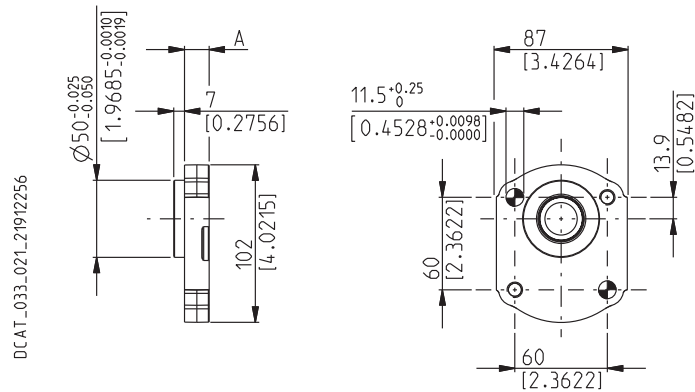

DRIVE SHAFTS
See page 26 ÷ 28

VERSIONS See page 21	A mm (in)	54	03	12	31	49	54	82
0	16 (0.63)	#	x	x	x	x	x	x
5	41,6 (1.6378)	x	x			x	x	x

Standard combination
x Available combination

01/06.2009

MOUNTING FLANGES AND TABLE OF COMPATIBILITY

GERMAN 4 BOLTS B6

Material: cast iron and aluminium

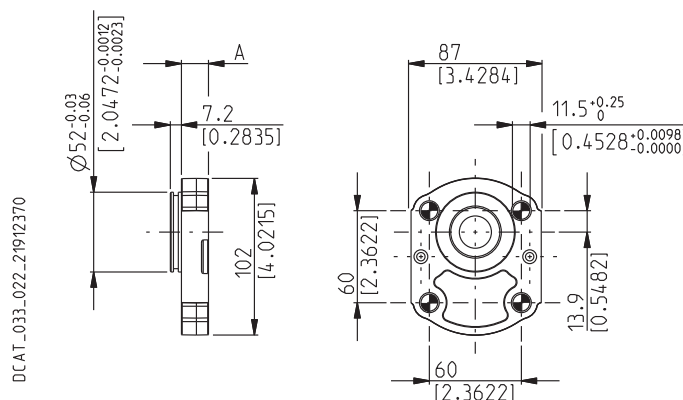

DCAT_033_022_21912370

DRIVE SHAFTS
See page 26 ÷ 28

VERSIONS See page 21	A mm (in)	95	07	12
0	17,7 (0.6968)	#	x	x
5	43,3 (1.747)	x		

Standard combination
x Available combination

SAE "A" 2 BOLTS S9

Material: cast iron and aluminium

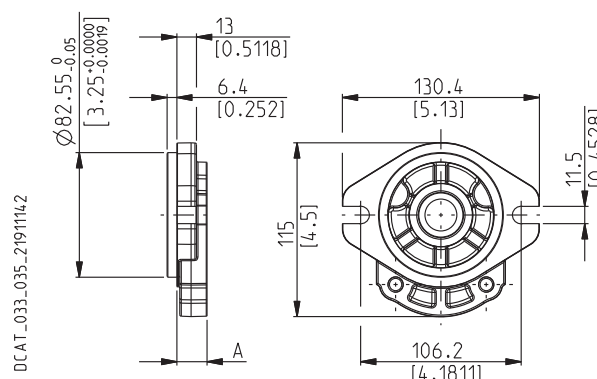

DCAT_033_035_21911142

DRIVE SHAFTS
See page 26 ÷ 28

VERSIONS See page 21	A mm (in)	01	03	04	07	12	31	32	46	49	50	54	82
0	20 (0.7874)	#	#	x	#	x	#	x	x	#	x	x	x
5	45,6 (1.7953)		x							x	x	x	x

Standard combination
x Available combination

01/06.2009

MOUNTING FLANGES AND TABLE OF COMPATIBILITY

SAE "A" 2 BOLTS

WD

Material: cast iron and aluminium

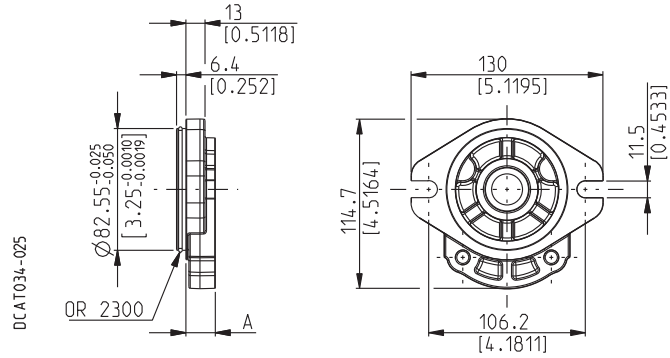

DRIVE SHAFTS

See page 26 ÷ 28

VERSIONS See page 21	A mm (in)	01	03	04	07	12	31	32	46	49	50	54	82
0	20 (0.7874)	#	#	x	#	x	#	x	x	#	x	x	x
5	45,6 (1.7953)		x							x	x	x	x

Standard combination
x Available combination

SAE "B" 2 BOLTS

S5

Material: cast iron

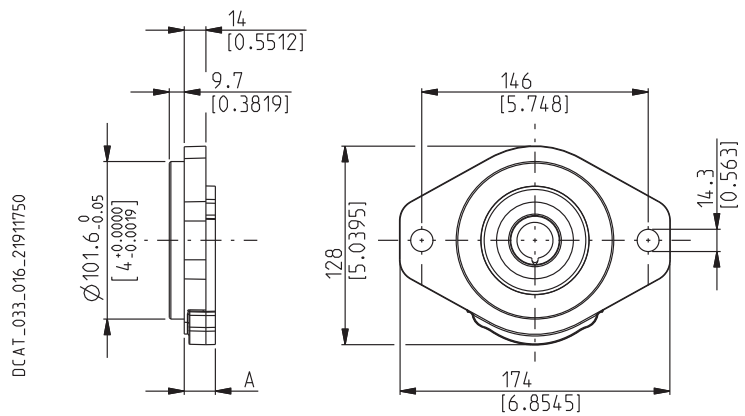

DRIVE SHAFTS

See page 26 ÷ 28

VERSIONS See page 21	A mm (in)	04	32	49
0	20 (0.7874)	#	#	x
5	45,6 (1.7953)			x

Standard combination
x Available combination

01/06.2009

MOUNTING FLANGES AND TABLE OF COMPATIBILITY

GERMAN **W8**

Material: cast iron

Replaces: 01/06.2009

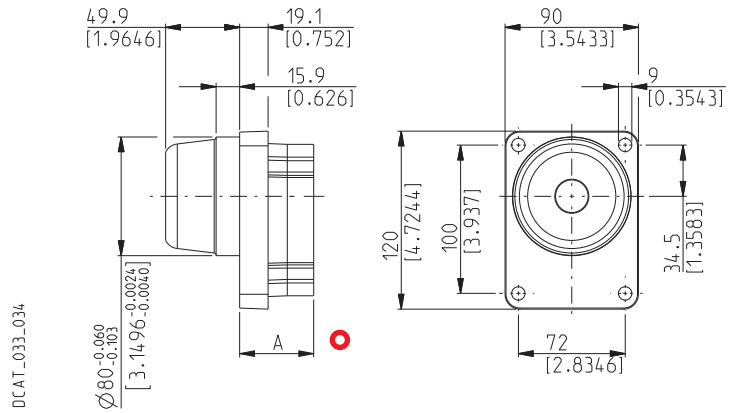

DRIVE SHAFTS

See page 26 ÷ 28

VERSIONS See page 21	A mm (in)	55
W8	● 49,8 (1.9606)	#

Standard combination
x Available combination

●

02/06.2010

IN/OUT PORTS TYPE

PORTS TYPE	SIDE PORTS												REAR PORTS			
	German		European		Split SSM		Split SSS		Gas BSPP		SAE ODT		Gas BSPP		SAE ODT	
Pump type	IN	OUT	IN	OUT	IN	OUT	IN	OUT	IN	OUT	IN	OUT	IN	OUT	IN	OUT
Motor type	OUT	IN	OUT	IN	OUT	IN	OUT	IN	OUT	IN	OUT	IN	OUT	IN	OUT	IN
PH. 20•19	BE	BC	EB	EA	MB	MA	SB	SA	GE	GD	OD	OC	GE	GD	OD	OC
PH. 20•20	BE	BC	EB	EA	MB	MA	SB	SA	GE	GD	OD	OC	GE	GD	OD	OC
PH. 20•23	BE	BC	EB	EA	MC	MB	SC	SB	GF	GD	OF	OC	GE	GD	OD	OC
PH. 20•24,5	BE	BC	EB	EA	MC	MB	SC	SB	GF	GD	OF	OC	GE	GD	OD	OC
PH. 20•25	BE	BC	EB	EA	MC	MB	SC	SB	GF	GD	OF	OC	GE	GD	OD	OC
PH. 20•27,8	BE	BC	EB	EA	MC	MB	SC	SB	GF	GD	OF	OC	GE	GD	OD	OC
PH. 20•31,5	BE	BC	EB	EA	MC	MB	SC	SB	GF	GD	OF	OC	GE	GD	OD	OC

Different inlet and outlet ports are available.
For more information please consult our technical sales department.

EXTERNAL DRAIN PORTS

IN/OUT PORTS YPE	SIDE PORTS						REAR PORTS	
	German	European	Split SSM	Split SSS	Gas BSPP	SAE ODT	Gas BSPP	SAE ODT
PH. 20	TA	GB	GB	03	GB	03	GB	03

Dimensions on page 37

IN/OUT PORTS SIZES

 Tightening torque for low pressure side port.



 Tightening torque for high pressure side port [values obtained at 5075 psi (350 bar)]

For reversible rotation, please consult only the tightening torque for high pressure side port.

GERMAN FLANGED PORTS - 4 Bolts

GERMAN

Metric thread ISO 60° conforms to ISO/R 262

CODE	A	B	C		
	mm (in)	mm (in)	Thread Depth mm (in)	Nm (lbf in)	Nm (lbf in)
BC	15 (0.5906)	35 (1.3780)	M 6 12 (0.4724)	8 ^{+0,5} (71 ÷ 75)	8 ^{+0,5} (71 ÷ 75)
BE	20 (0.7874)	40 (1.5748)	M 6 12 (0.4724)	8 ^{+0,5} (71 ÷ 75)	8 ^{+0,5} (71 ÷ 75)

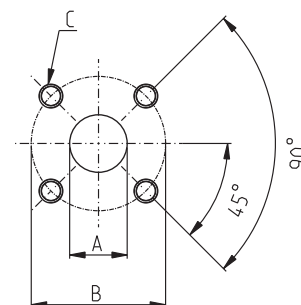

DCAT_033_028_17667888



EUROPEAN FLANGED PORTS - 4 Bolts

EUROPEAN

Metric thread ISO 60° conforms to ISO/R 262

CODE	A	B	C		
	mm (in)	mm (in)	Thread Depth mm (in)	Nm (lbf in)	Nm (lbf in)
EA	13 (0.5118)	30 (1.1811)	M 6 13 (0.5118)	8 ^{+0,5} (71 ÷ 75)	8 ^{+0,5} (71 ÷ 75)
EB	19 (0.7480)	40 (1.5748)	M 8 14 (0.5512)	15 ⁺¹ (133 ÷ 142)	20 ⁺¹ (177 ÷ 186)

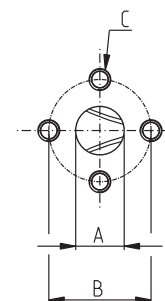

DCAT_006_024_21060533



SAE FLANGED PORTS J518 - Standard pressure series 3000 PSI

SSM

Metric thread ISO 60° conforms to ISO/R 262

CODE	A	B	C	D		
	mm (in)	mm (in)	mm (in)	Thread Depth mm (in)	Nm (lbf in)	Nm (lbf in)
MA	12,5 (0.4921)	38,1 (1.50)	17,5 (0.6890)	M 8 14 (0.5512)	15 ⁺¹ (133 ÷ 142)	15 ⁺¹ (133 ÷ 142)
MB	19 (0.7480)	47,6 (1.8740)	22,2 (0.8740)	M 10 14 (0.5512)	20 ⁺¹ (177 ÷ 186)	25 ⁺¹ (266 ÷ 288)
MC	25,4 (1.0000)	52,4 (2.0630)	26,2 (1.0315)	M 10 14 (0.5512)	20 ⁺¹ (177 ÷ 186)	25 ⁺¹ (266 ÷ 288)

DCAT_006_025_21064252

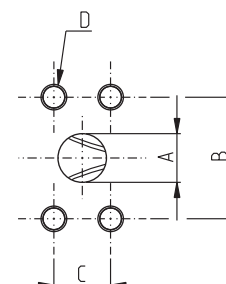

01/06.2009

IN/OUT PORTS SIZES

 Tightening torque for low pressure side port.



 Tightening torque for high pressure side port [values obtained at 5075 psi (350 bar)]

For reversible rotation, please consult only the tightening torque for high pressure side port.

SAE FLANGED PORTS J518 - Standard pressure series 3000 PSI

SSS

American straight thread UNC-UNF 60° conforms to ANSI B 1.1

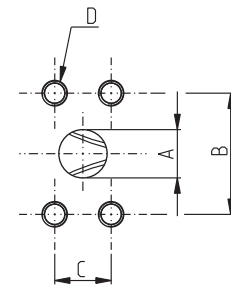

CODE	A	B	C	D		
	mm (in)	mm (in)	mm (in)	Thread Depth mm (in)	Nm (lbf in)	Nm (lbf in)
SA	12,5 (0.4921)	38,1 (1.50)	17,5 (0.6890)	5/16-18 UNC-2B 14 (0.5512)	15 ⁺¹ (133 ÷ 142)	15 ⁺¹ (133 ÷ 142)
SB	19 (0.7480)	47,6 (1.8740)	22,2 (0.8740)	3/8 - 16 UNC-2B 14 (0.5512)	20 ⁺¹ (177 ÷ 186)	20 ⁺¹ (177 ÷ 186)
SC	25,4 (1.0000)	52,4 (2.0630)	26,2 (1.0315)	3/8 - 16 UNC-2B 14 (0.5512)	20 ⁺¹ (177 ÷ 186)	25 ⁺¹ (221 ÷ 230)



GAS STRAIGHT THREAD PORTS

BSPB

British standard pipe parallel (55°) conforms to UNI - ISO 228

CODE	Nominal size	A	Ø B	Ø C	D	E		
			mm (in)	mm (in)	mm (in)	mm (in)	Nm (lbf in)	Nm (lbf in)
GD	1/2"	G 1/2	-	19 (0.7480)	17 (0.6693)	-	20 ⁺¹ (177 ÷ 186)	50 ^{+2,5} (443 ÷ 465)
GE	3/4"	G 3/4	-	24,5 (0.9646)	18 (0.7087)	-	30 ^{+2,5} (266 ÷ 288)	90 ⁺⁵ (797 ÷ 841)
GF	1"	G 1	-	30,5 (1.2008)	18 (0.7087)	-	50 ^{+2,5} (443 ÷ 465)	130 ⁺¹⁰ (1151 ÷ 1239)

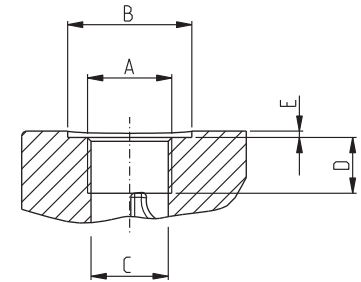

DCAT_006_026_21064779



SAE STRAIGHT THREAD PORTS J514

ODT

American straight thread UNC-UNF 60° conforms to ANSI B 1.1

CODE	Nominal size	A	Ø B	Ø C	D	E		
			mm (in)	mm (in)	mm (in)	mm (in)	Nm (lbf in)	Nm (lbf in)
OC	5/8"	7/8" - 14 UNF - 2B	35 (1.3780)	20,5 (0.8071)	17 (0.6693)	0,5 (0.0197)	30 ^{+2,5} (266 ÷ 288)	70 ⁺⁵ (620 ÷ 664)
OD	3/4"	1 1/16" - 12 UNF - 2B	42 (1.6535)	24,8 (0.9764)	20 (0.7874)	0,5 (0.0197)	40 ^{+2,5} (354 ÷ 376)	120 ⁺¹⁰ (1062 ÷ 1151)
OF	1"	1 5/16" - 12 UNF - 2B	49 (1.9291)	30,5 (1.2008)	20 (0.7874)	0,5 (0.0197)	60 ⁺⁵ (531 ÷ 575)	170 ⁺¹⁰ (1505 ÷ 1593)

DCAT_006_027_21060524

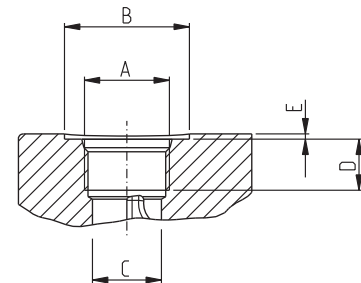

01/06.2009

DRAIN PORTS SIZES

 Tightening torque for low pressure side port.

GAS STRAIGHT THREAD PORTS

BSPP

British standard pipe parallel (55°) conforms to UNI - ISO 228

CODE	Nominal size	A	∅ B	∅ C	D	E	 Nm (lbf in)
			mm (in)	mm (in)	mm (in)	mm (in)	
GB	1/4"	G 1/4	21,5 (0.8465)	12 (0.4724)	15 (0.5906)	1,5 (0.0591)	15 ⁺¹ (133 ÷ 142)

DCAT_006_026_21064779

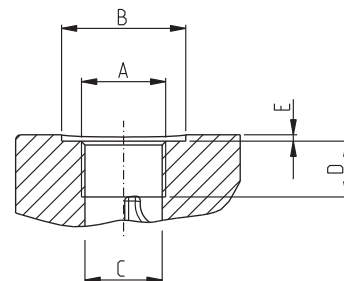

METRIC STRAIGHT THREAD PORTS ISO 6149

METRIC

Metric thread ISO 60° conforms to ISO/R 262

CODE	A	∅ B	∅ C	D	E	 Nm (lbf in)
		mm (in)	mm (in)	mm (in)	mm (in)	
TA	M 10x1	22 (0.8661)	9 (0.3543)	13 (0.5118)	0,5 (0.0197)	10 ^{+0,5} (89 ÷ 93)

DCAT_006_026_21064779

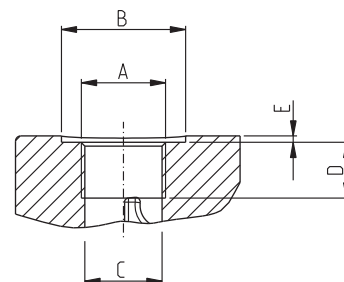

SAE STRAIGHT THREAD PORTS J514

ODT

American straight thread UNC-UNF 60° conforms to ANSI B 1.1

CODE	A	∅ B	∅ C	D	E	 Nm (lbf in)
		mm (in)	mm (in)	mm (in)	mm (in)	
03	7/16"-20 UNF-2B	21 (0.8267)	9,5 (0.3740)	14 (0.5512)	1 (0.0394)	12 ⁺¹ (106 ÷ 115)

DCAT_006_027_21060524

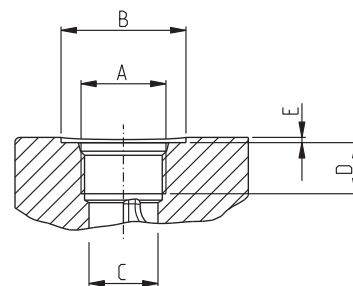

01/06.2009

VALVE OPTIONS (◆)

Replaces: 01/06.2009

02/06.2010

PRIORITY VALVE

P1

Constant delivery and internal recirculation of excess flow.

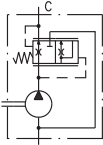

P2

Constant delivery at controlled pressure. Internal recirculation of excess flow and drain valve.

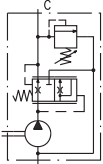

P3

Constant delivery at controlled pressure. Excess flow and drain valve must be connected to tank.

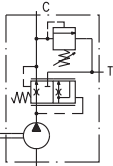

P4

Constant delivery and excess flow can both be used under load.

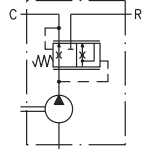

P5T

Constant delivery at controlled pressure with drain valve connected to tank. Excess flow can be used under load.

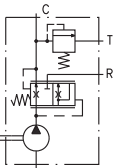

ELECTRIC VALVE FOR MOTORS

EC08..

By-pass valve normally closed with max. pressure relief valve and anti-cavitation valve.

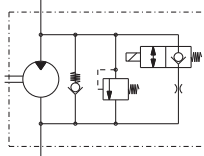

DBVSA..

Proportional relief valve and anti-cavitation valve.

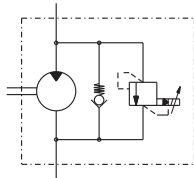

ER12-A

Reverse valve with proportional relief valve and anti-cavitation valve.



MAX PRESSURE RELIEF VALVE

VPEF..

Fixed setting with external drain.

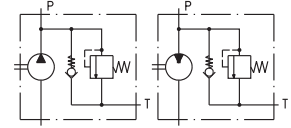

VPIF..

Fixed setting with internal drain.

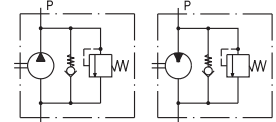

VPER..

Adjustable setting with external drain.

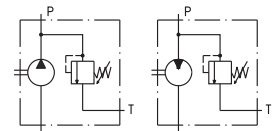

VPIR..

Adjustable setting with internal drain.

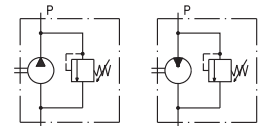

LOAD SENSING VALVE

...

Static.

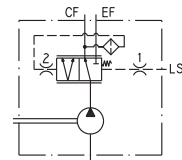

...

Dynamic.

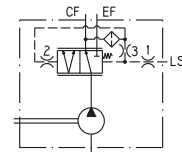

...

Dynamic with relief valve fitted on the main line.

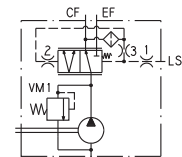

...

Dynamic with relief valve fitted on controlled line.

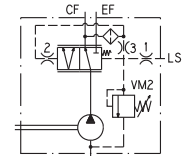

CHECK VALVE

V8

Anti-cavitation valve.

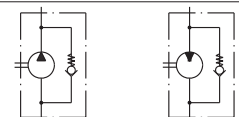

(◆) For more information please consult our built-in valves technical catalogue and our sales department.

INSTRUCTIONS

INSTALLATION

Pump

The direction of rotation of single-rotation pumps must be the same as that of the drive shaft. Check that the coupling flange correctly aligns the transmission shaft and the pump shaft. Flexible couplings should be used (never rigid fittings) which will not generate an axial or radial load on the pump shaft.

Motor

The direction of rotation of single-rotation motors must match circuit connections. Check that the coupling flange correctly aligns the transmission shaft and the motor shaft. Flexible couplings should be used (never rigid fittings) which will not generate an axial or radial load on the motor shaft.

TANK

Tank capacity must be sufficient for the system's operating conditions (~ 3 times the amount of oil in circulation) to avoid overheating of the fluid. A heat exchanger should be installed if necessary. The intake and return lines in the tank must be spaced apart (by inserting a vertical divider) to prevent the return-line oil from being taken up again immediately.

LINES

The lines must have a major diameter which is at least as large as the diameter of pump or motor ports, and must be perfectly sealed. To reduce loss of power, the lines should be as short as possible, reducing the sources of hydraulic resistance (elbow, throttling, gate valves, etc.) to a minimum. A length of flexible tubing is recommended to reduce the transmission of vibrations. All return lines must end below the minimum oil level, to prevent foaming. Before connecting the lines, remove any plugs and make sure that the lines are perfectly clean.

FILTERS

We recommend filtering the entire system flow. Filters on suction and return line must be fitted in according to the contamination class as indicated in the first pages of the catalogue. Casappa recommends to use its own production filters:



HYDRAULIC FLUID

Use hydraulic fluid conforming to ISO/DIN standards, having viscosity as specified in the first pages of the catalogue. Avoid using mixtures of different oils which could result in decomposition and reduction of the oil's lubricating power.

STARTING UP

Check that all circuit connections are tight and that the entire system is completely clean. Insert the oil in the tank, using a filter. Bleed the circuit to assist in filling. Set the pressure relief valves to the lowest possible setting. Turn on the system for a few moments at minimum speed, then bleed the circuit again and check the level of oil in the tank. If the difference between pump or motor temperature and fluid temperature exceeds 50 °F (10 °C), rapidly switch the system on and off to heat it up gradually. Then gradually increase the pressure and speed of rotation until the pre-set operating levels as specified in the catalogue are attained.

PERIODICAL CHECKS - MAINTENANCE

Keep the outside surface clean especially in the area of the drive shaft seal. In fact, abrasive powder can accelerate wear on the seal and cause leakage. Replace filters regularly to keep the fluid clean. The oil level must be checked and oil replaced periodically depending on the system's operating conditions.

HOW TO ORDER POLARIS PH. 20 SINGLE UNITS

1
2
3
4
5
6
7
8
9
10
11
12
13
PHP20-19 - L 0 82 E2 - L - EB/EA - N EL C * - GB - FS

1	Type	PUMP TYPE	MOTOR TYPE
	in ³ /rev (cm ³ /rev)		
	1.16 (19,09)	PHP 20•19	PHM 20•19
	1.29 (21,14)	PHP 20•20	PHM 20•20
	1.42 (23,32)	PHP 20•23	PHM 20•23
	1.52 (24,84)	PHP 20•24,5	PHM 20•24,5
	1.61 (26,42)	PHP 20•25	PHM 20•25
	1.72 (28,21)	PHP 20•27,8	PHM 20•27,8
	2.01 (33,03)	PHP 20•31,5	PHM 20•31,5

2	Rotation	CODE
	Left	S
	Right	D
	Reversible rear external drain	R
	Reversible side external drain	L
	Reversible internal drain	B

3	Version	CODE
	Without outboard bearing	0
	With outboard bearing	W8
	With outboard bearing	4
	With outboard bearing	5
	With outboard bearing	6
	With outboard bearing	7
	With outboard bearing	8
	With outboard bearing	9

4	Drive shaft	CODE
	European tapered 1:8	82
	German tapered 1:5	54
	German tapered 1:5	55
	Straight	46
	SAE "A" spline (9 teeth)	03
	SAE spline (10 teeth)	01
	SAE "A" spline (11 teeth)	07
	SAE "A" straight	31
	Straight	49
	Straight	50
	SAE "B" spline	04
	SAE "B" straight	32
	DIN 54 82 spline	12
	Straight (only for version 6)	48
	Straight (only for version 8)	B1
	Tang	95

CODE	Mounting flange	5
E2	European	
B2	German	
B4	German 2 bolt	
B5	German 2 bolt	
B6	German 4 bolt	
S9	SAE "A" 2 bolt	
WD	SAE "A" 2 bolt	
S5	SAE "B" 2 bolt	
W8	German	

CODE	Ports position	6
L	Side	
P	Rear	

CODE	Ports IN/OUT		7
GERMAN FLANGED PORTS			
Side	Rear	Type	
BE/BC		PHP 20	19-20-23-24,5 25-27,8-31,5
BC/BE		PHM 20	
EUROPEAN FLANGED PORTS			
Side	Rear	Type	
EB/EA		PHP 20	19-20-23-24,5 25-27,8-31,5
EA/EB		PHM 20	
SAE FLANGED PORTS (SSM)			
Side	Rear	Type	
MB/MA		PHP 20	19-20 23-24,5-25-27,8-31,5
MA/MB		PHM 20	
MC/MB		PHP 20	
MB/MC		PHM 20	
SAE FLANGED PORTS (SSS)			
Side	Rear	Type	
SB/SA		PHP 20	19-20 23-24,5-25-27,8-31,5
SA/SB		PHM 20	
SC/SB		PHP 20	
SB/SC		PHM 20	
GAS STRAIGHT THREAD PORTS (BSPP)			
Side	Rear	Type	
GE/GD	GE/GD	PHP 20	19-20 23-24,5-25-27,8-31,5
GD/GE	GD/GE	PHM 20	
GF/GD	GE/GD	PHP 20	
GD/GF	GD/GE	PHM 20	
SAE STRAIGHT THREAD PORTS (ODT)			
Side	Rear	Type	
OD/OC	OD/OC	PHP 20	19-20 23-24,5-25-27,8-31,5
OC/OD	OC/OD	PHM 20	
OF/OC	OD/OC	PHP 20	
OC/OF	OC/OD	PHM 20	

01/06.2009

HOW TO ORDER POLARIS PH. 20 SINGLE UNITS

8	Seals (a)	CODE
	Buna (standard)	N
	Viton	V

9	Cover options (b)	CODE
	Cast iron mounting flange and rear cover (standard - no code)	
	Aluminium mounting flange and cast iron rear cover	E
	Cast iron mounting flange and aluminium rear cover	L
	Aluminium mounting flange and rear cover	EL

10	Shaft seal options	CODE
	High back pressure seal with wiper seal	C
	Standard seal with wiper seal	D
	High back pressure seal	H

11	Drain port position - Rev. rotation L	CODE
	Side drain with side port position	L
	Side drain with bottom port position	*

CODE	Drain port		12
IN/OUT GERMAN FLANGED PORTS			
Side	Rear	Type	
TA		PHP 20	19-20-23-24,5
		PHM 20	25-27,8-31,5
IN/OUT EUROPEAN FLANGED PORTS			
Side	Rear	Type	
GB		PHP 20	19-20-23-24,5
		PHM 20	25-27,8-31,5
IN/OUT SAE FLANGED PORTS (SSM)			
Side	Rear	Type	
GB		PHP 20	19-20-23-24,5
		PHM 20	25-27,8-31,5
IN/OUT SAE FLANGED PORTS (SSS)			
Side	Rear	Type	
03		PHP 20	19-20-23-24,5
		PHM 20	25-27,8-31,5
IN/OUT GAS STRAIGHT THREAD PORTS (BSPP)			
Side	Rear	Type	
GB	GB	PHP 20	19-20-23-24,5
		PHM 20	25-27,8-31,5
IN/OUT SAE STRAIGHT THREAD PORTS (ODT)			
Side	Rear	Type	
03	03	PHP 20	19-20-23-24,5
		PHM 20	25-27,8-31,5

CODE	Shaft arrangement	13
FS	Female spline	

- (a) Choose the seals according to the temperature shown on page 2.
- (b) Mounting flange available in cast iron and aluminium. See material on page 29 ÷ 33
Rear cover material on page 12 ÷ 13

HOW TO ORDER POLARIS PHP 20 DOUBLE PUMPS

1

2

3

4

5

6

7

8

9

10

11

12

PHP20•19 – 82 E2 – L EB/EA /

Front section

20•19 – L **/EA – S7 – S 0 N L C FS

Rear section

1	Type	
	in ³ /rev (cm ³ /rev)	PUMP TYPE
	1.16 (19,09)	PHP 20•19
	1.29 (21,14)	PHP 20•20
	1.42 (23,32)	PHP 20•23
	1.52 (24,84)	PHP 20•24,5
	1.61 (26,42)	PHP 20•25
	1.72 (28,21)	PHP 20•27,8
	2.01 (33,03)	PHP 20•31,5

2	Drive shaft	CODE
	European tapered 1:8	82
	German tapered 1:5	54
	German tapered 1:5	55
	Straight	46
	SAE "A" spline (9 teeth)	03
	SAE spline (10 teeth)	01
	SAE "A" spline (11 teeth)	07
	SAE "A" straight	31
	Straight	49
	Straight	50
	SAE "B" spline	04
	SAE "B" straight	32
	DIN 54 82 spline	12
	Straight (only for version 6)	48
	Straight (only for version 8)	B1
	Tang	95

3	Mounting flange	CODE
	Europea	E2
	German	B2
	German 2 bolt	B4
	German 2 bolt	B5
	German 4 bolt	B6
	SAE "A" 2 bolt	S9
	SAE "A" 2 bolt	WD
	SAE "B" 2 bolt	S5
	German	W8

4	Ports position	CODE
	Side	L

CODE	Ports IN/OUT		5
GERMAN FLANGED PORTS			
Side	Type		
BE/BC	PHP 20	19-20-23-24,5 25-27,8-31,5	

EUROPEAN FLANGED PORTS			
Side	Type		
EB/EA	PHP 20	19-20-23-24,5 25-27,8-31,5	

SAE FLANGED PORTS (SSM)			
Side	Type		
MB/MA	PHP 20	19-20	
MC/MB	PHP 20	23-24,5-25-27,8-31,5	

SAE FLANGED PORTS (SSS)			
Side	Type		
SB/SA	PHP 20	19-20	
SC/SB	PHP 20	23-24,5-25-27,8-31,5	

GAS STRAIGHT THREAD PORTS (BSPP)			
Side	Type		
GE/GD	PHP 20	19-20	
GF/GD	PHP 20	23-24,5-25-27,8-31,5	

SAE STRAIGHT THREAD PORTS (ODT)			
Side	Type		
OD/OC	PHP 20	19-20	
OF/OC	PHP 20	23-24,5-25-27,8-31,5	

01/06.2009

HOW TO ORDER POLARIS PHP 20 DOUBLE PUMPS

6	Combination type	CODE
	Standard	S6
	Common inlet	S7
	Separate stages	Z6

7	Rotation	CODE
	Left	S
	Right	D

8	Version	CODE
	Without outboard bearing (standard) no code	0
	With outboard bearing	W8
	With outboard bearing	4
	With outboard bearing	5
	With outboard bearing	6
	With outboard bearing	7
	With outboard bearing	8
	With outboard bearing	9

CODE	Seals (a)	9
N	Buna (standard)	
V	Viton	

CODE	Cover options (b)	10
	Cast iron mounting flange and rear cover (standard - no code)	
L	Cast iron mounting flange and aluminium rear cover	

CODE	Shaft seal options	11
C	High back pressure seal with wiper seal	
D	Standard seal with wiper seal	
H	High back pressure seal	

CODE	Shaft arrangement	12
FS	Female spline	

- (a) Choose the seals according to the temperature shown on page 2.
 (b) Mounting flange available in cast iron only.
 Rear cover available in cast iron and aluminium.

HOW TO ORDER POLARIS DOUBLE PUMPS DIFFERENT GROUPS

PHP20 / PLP20

1	2	3	4	5	6	7	8	9	10	11
Pump type	Drive shaft	Mount. flange	Ports posit.	Ports IN/OUT	Comb. type	Rotation	Version	Shaft arrang.	Cover options	Seals

PHP20•19 - 82 E2 - L EB/EA /

Front section

PLP20•4 - L EA/EA - S - 0 - FS - L - N

Rear section

PHP20 / PLP10

PHP20•19 - 82 E2 - L EA/EA - 51 /

Front section

PLP 10•1 - L BB/BA - S - 0 - FS - EL - N

Rear section

1	Type (a)	PUMP TYPE
	in ³ /rev (cm ³ /rev)	
	The same of double pumps	PHP ..
2	Drive shaft	CODE
	The same of double pumps	...
3	Mounting flange	CODE
	The same of double pumps	...
4	Ports position	CODE
	Side	L
5	Ports IN/OUT	CODE
	The same of double pumps	../.
6	Combination type	CODE
	PHP20/PLP20 Standard - No code	S6
	PHP20/PLP20 Common inlet	S7
	PHP20/PLP20 Separate stages	Z6
	PHP20/PLP10 Standard - No code	T6
	PHP20/PLP10 Common inlet	T7
	PHP20/PLP10 Separate stages	Z6

CODE	Rotation	7
S	Left	
D	Right	

CODE	Version	8
...	The same of double pumps	

CODE	Shaft arrangement	9
FS	Female spline	

CODE	Cover options (b)	10
	Cast iron mounting flange and rear cover (standard - no code)	
E	Aluminium mounting flange and cast iron rear cover	
L	Cast iron mounting flange and aluminium rear cover	
EL	Aluminium mounting flange and rear cover	

CODE	Seals	11
	The same of multiple pumps	

(a) For PLP 20 and PLP 10 features please consult the proper technical catalogue.

(b) Mounting flange available in cast iron and aluminium. See material on page 29 ÷ 33

01/06.2009

Our policy is one of continuous improvement in product. Specification of item may, therefore, be changed without notice.

PH 02 T A

Edition: 02/06.2010

Replaces: PH 01 T A



Headquarters:

CASAPPA S.p.A.

Via Balestrieri, 1

43044 Lemignano di Collecchio

Parma (Italy)

Tel. +39 0521 30 41 11

Fax +39 0521 80 46 00

IP Videoconferencing

E-mail: info@casappa.com

www.casappa.com

