



Scanwill

Fluid Power ApS

The MP-Series of Hydraulic Pressure Intensifiers



- Hydraulic Workholding on Machine Tools
- Static and Impulse Testing Equipment
- Hydraulic Power Packs
- Stone Chushing Machines
- Subsea R.O.V.'s
- Hydraulic Construction Tools
- Press Applications
- Demolition Tools
- Pressure Die Casting Machines
- Quick Die Changing Equipment





The Function of the MP-Series

The Function

The MP-Series of hydraulic pressure intensifiers are reciprocating, and will automatically increase a supplied pressure to a higher end pressure.

Fig. 1 shows the basic principle of the intensifiers, consisting of a piston arrangement and a Piston Control Valve, PCV. The position of the pistons will at the end of every stroke prompt a signal S to the PCV, which makes this change position, ensuring the pistons are moving in the opposite direction. This cycle will continue until the end pressure has been reached. At this point the pistons stop, and will now only move to maintain the end pressure.

General Data

- Material: Cast Iron and steel (also available in stainless steel)
- Surface coating: Chromit blue finish
- Fluids: Recognised hydraulic fluids and water glycol (water and other fluids are possible)
- Filtration: 10 μ nominal, maximum 19/16 according to ISO 4406

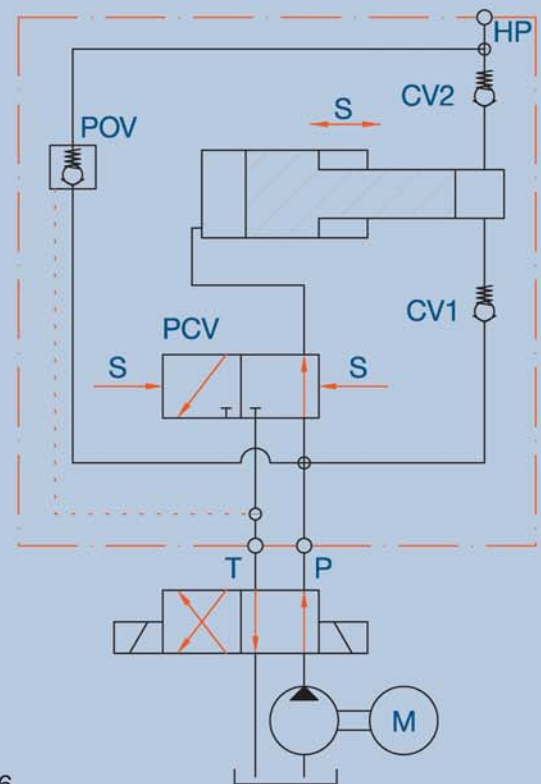

Fig. 1



The Cycle

When a hydraulic fluid is supplied to the P-connection of the intensifier and the T-connection is connected to tank, the oil will be directed through the check valves CV1 and CV2 to the high pressure connection HP. If the internal pilot operated check valve POV is incorporated the oil will go straight to the HP connection. In this situation all the flow supplied goes to the high pressure side ensuring a fast filling of the system.

When pump pressure has been reached, the intensifier pistons will deliver the flow to the high pressure side, and continue to do so until the required end pressure has been reached. The pistons then stop, and will only move to make up for a pressure loss due to leakage or consumption. A general flow-pressure curve for the intensifier is shown in Fig.2.

For evacuating the high pressure side the internal POV is used. This valve is opened by directing the supplied pressure to the T-port and connecting the P-port to tank. This allows the oil from the high pressure side to flow directly back to tank.

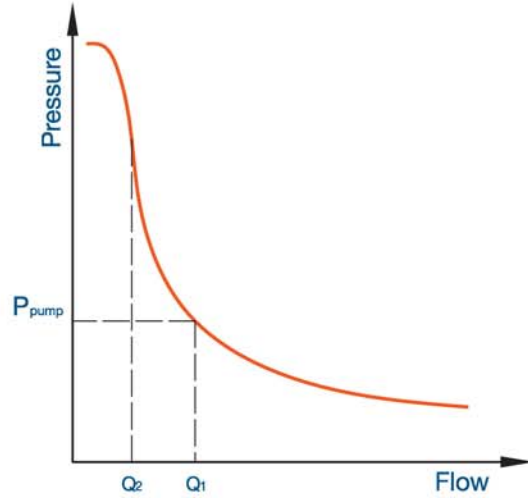

Fig. 2

The Cycle and Overview

Intensifier Model	Mounting	Max. Inlet flow (LPM / GPM)	Max. Supply Pressure (bar / psi)	Max. Output pressure (bar / psi)	Details
MP-T 	in-line	15 / 4.0	200 / 3,000	800 / 11,600	page 4
MP-C 	cetop /NG6	15 / 4.0	200 / 3,000	500 / 7,250	page 5
MP-F 	flange on	15 / 4.0	200 / 3,000	700 / 10,150	page 6
MP-M 	in-line	35 / 9.3	200 / 3,000	800 / 11,600	page 7
MP-L 	in-line	80 / 21.2	200 / 3,000	800 / 11,600	page 8
MP-2000 	in-line	13 / 3.4	200 / 3,000	3,000 / 43,500	page 9
MPL-1400 	in-line	50 / 13.1	200 / 3,000	1,400 / 20,300	page 10
MPL-2000 	in-line	25 / 6.5	200 / 3,000	2,800 / 40,600	page 10
MPL-4000 	in-line	25 / 6.5	200 / 3,000	4,000 / 60,000	page 10

- In-Line Pressure Intensifier
- End pressure up to 800 bar / 11,600 psi
- Multiple intensification ratios available
- Reciprocating - delivers continuous flow during pressure build up
- All high pressure valves are integrated

The MP-T Pressure Intensifier

Ratio (i)	Max. Inlet flow (LPM / GPM)	Outlet Flow Q1 (LPM / GPM)	Outlet Flow Q2 (LPM / GPM)	Max. Supply Pressure (bar / psi)	Max. Output Pressure (bar / psi)
1.5	8.0 / 2.1	0.8 / 0.21	0.3 / 0.08	200 / 2,900	300 / 4,350
2.0	8.0 / 2.1	0.8 / 0.21	0.2 / 0.08	200 / 2,900	400 / 5,800
3.4	15.0 / 4.0	2.2 / 0.58	0.5 / 0.13	200 / 2,900	680 / 9,860
4.0	14.0 / 3.7	1.8 / 0.47	0.4 / 0.10	200 / 2,900	800 / 11,600
5.0	14.0 / 3.7	1.4 / 0.37	0.3 / 0.08	160 / 2,320	800 / 11,600
7.0	13.0 / 3.4	1.1 / 0.29	0.2 / 0.05	114 / 1,653	800 / 11,600
9.0	13.0 / 3.4	0.7 / 0.19	0.1 / 0.03	89 / 1,290	800 / 11,600

Weight: 1.3 kgs

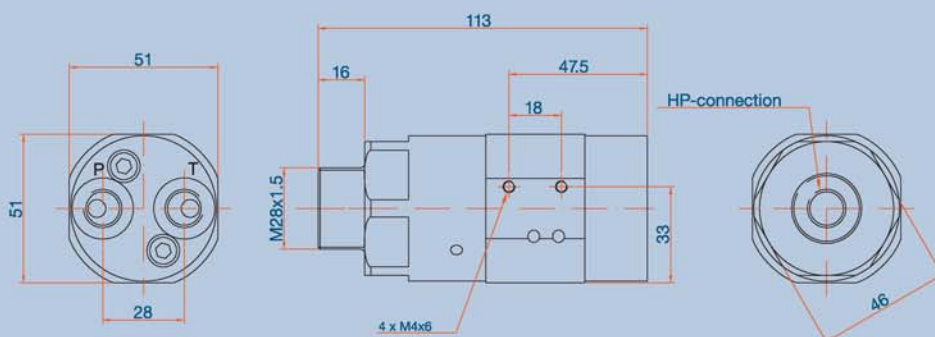

Dimensions in mm

Also available with M24x1.5 thread.

Ordering Code *

MP-T -		-		-	
POV		Supply side		High press. side	
No	S	G	G1/4"	G1/4"	
Yes	P	U	7/16-20 UNF	9/16-18 UNF	
Intensification					
1.5	2.0	3.4	4.0	5.0	7.0 9.0

Example

MP-T with POV, intensification 5.0 and BSP connections: MP-T-P-5.0-G

* First decide whether the pilot operated check valve, POV, is required. Then decide the intensification ratio (i), and finally decide the connections (BSP or UNF).





- Cetop DO3 / NG6 Pressure Intensifier
- End pressure up to 500 bar / 7,000 psi
- Multiple intensification ratios available
- Reciprocating - delivers continuous flow during pressure build up
- All high pressure valves are integrated including a p.o. check valve

The MP-C Pressure Intensifier

Ratio (i)	Max. Inlet flow (LPM / GPM)	Outlet Flow Q1 (LPM / GPM)	Outlet Flow Q2 (LPM / GPM)	Max. Supply Pressure (bar / psi)	Max. Output Pressure (bar / psi)
1.5	8.0 / 2.1	0.8 / 0.21	0.3 / 0.08	200 / 2,900	300 / 4,350
2.0	8.0 / 2.1	0.8 / 0.21	0.2 / 0.08	200 / 2,900	400 / 5,800
3.4	15.0 / 4.0	2.2 / 0.58	0.5 / 0.13	147 / 2,132	500 / 7,250
4.0	14.0 / 3.7	1.8 / 0.47	0.4 / 0.10	125 / 1,812	500 / 7,250
5.0	14.0 / 3.7	1.4 / 0.37	0.3 / 0.08	100 / 1,450	500 / 7,250
7.0	13.0 / 3.4	1.1 / 0.29	0.2 / 0.05	71 / 1,036	500 / 7,250
9.0	13.0 / 3.4	0.7 / 0.19	0.1 / 0.03	56 / 806	500 / 7,250

Weight : 2.7 kgs

Ordering code

Intensification							
1.5	2.0	3.4	4.0	5.0	7.0	9.0	

Example

MP-C with intensification 4.0: MP-C-4.0

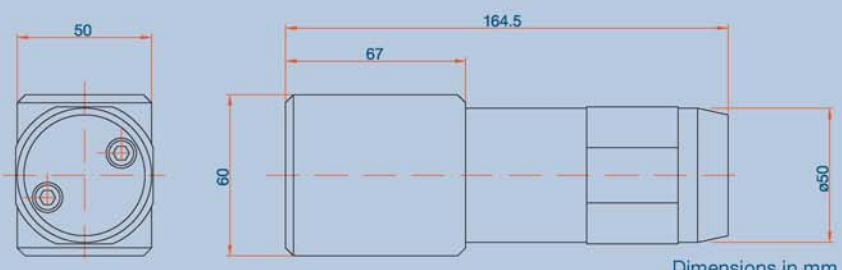
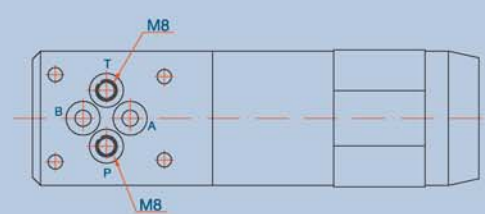

- Flange-On pressure intensifier
- End pressure up to 700 bar / 10,000 psi
- Multiple intensification ratios available
- Reciprocating - delivers continuous flow during pressure build up
- All high pressure valves are integrated including a p.o. check valve

The MP-F Pressure Intensifier

Ratio (i)	Max. Inlet flow (LPM / GPM)	Outlet Flow Q1 (LPM / GPM)	Outlet Flow Q2 (LPM / GPM)	Max. Supply Pressure (bar / psi)	Max. Output Pressure (bar / psi)
2.0	8.0 / 2.1	0.8 / 0.21	0.2 / 0.08	200 / 2,900	400 / 5,800
3.4	15.0 / 4.0	2.2 / 0.58	0.5 / 0.13	200 / 2,900	680 / 9,860
4.0	14.0 / 3.7	1.8 / 0.47	0.4 / 0.10	175 / 2,538	700 / 10,150
5.0	14.0 / 3.7	1.4 / 0.37	0.3 / 0.08	140 / 2,030	700 / 10,150
7.0	13.0 / 3.4	1.1 / 0.29	0.2 / 0.05	100 / 1,450	700 / 10,150

Weight : 1.4 kgs

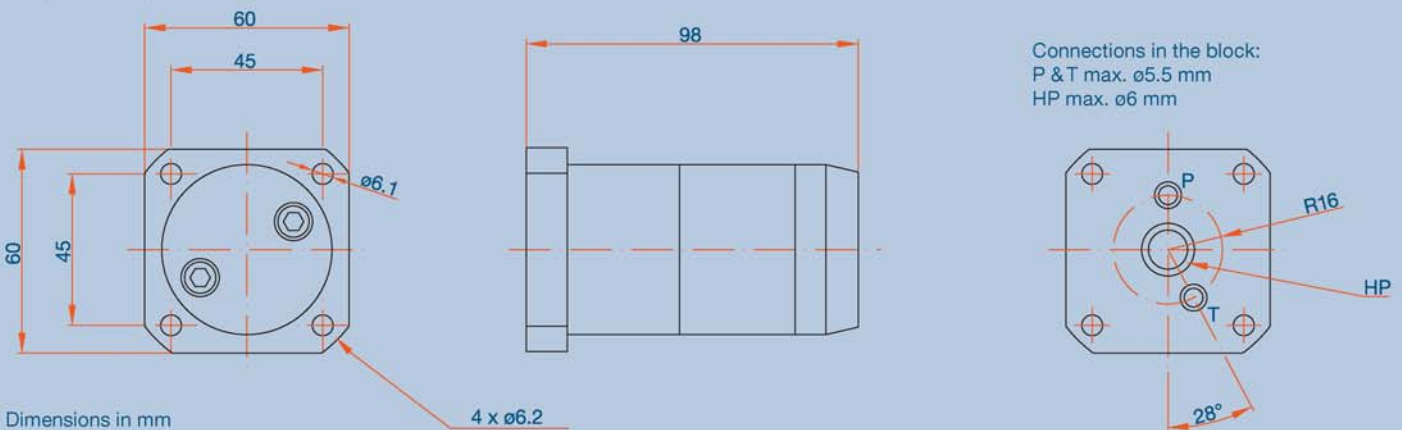

Ordering code

Intensification				
2.0	3.4	4.0	5.0	7.0

Example

MP-F with intensification 3.4: MP-F-3.4





- In-Line Pressure Intensifier
- End pressure up to 800 bar / 11,600 psi
- Multiple intensification ratios available
- Reciprocating - delivers continuous flow during pressure build up
- All high pressure valves are integrated including a p.o. check valve

The MP-M Pressure Intensifier

Ratio (i)	Max. Inlet flow (LPM / GPM)	Outlet Flow Q1 (LPM / GPM)	Outlet Flow Q2 (LPM / GPM)	Max. Supply Pressure (bar / psi)	Max. Output Pressure (bar / psi)
1.8	25.0 / 6.6	5.0 / 1.32	1.5 / 0.39	200 / 2,900	360 / 5,220
3.4	35.0 / 9.3	5.0 / 1.32	2.8 / 0.74	200 / 2,900	680 / 9,860
4.0	35.0 / 9.3	4.0 / 1.06	2.4 / 0.63	200 / 2,900	800 / 11,600
5.0	35.0 / 9.3	3.5 / 0.93	1.9 / 0.50	160 / 2,320	800 / 11,600
7.0	35.0 / 9.3	3.0 / 0.80	1.3 / 0.34	114 / 1,450	800 / 11,600

Weight : 3.5 kgs

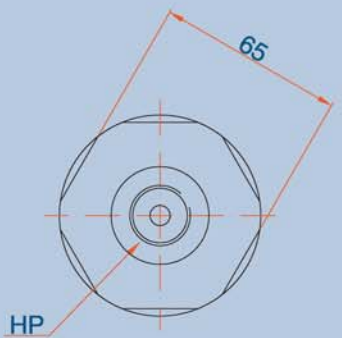
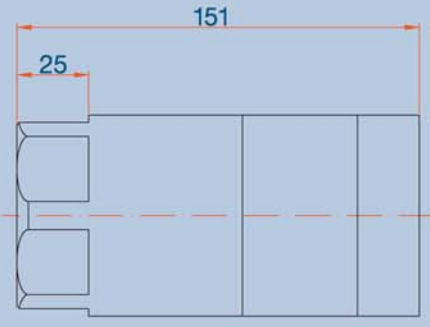
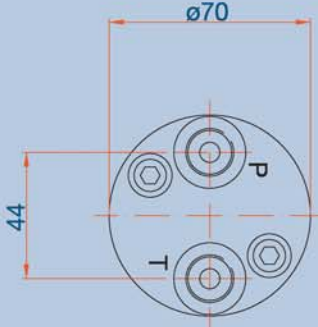

P & T: G3/8" (3/8" BSP)
 HP: G1/2" (1/2" BSP)

Dimensions in mm

Ordering code

Intensification					
1.8	3.4	4.0	5.0	7.0	

Example

MP-M with intensification 7.0: MP-M-7.0



- In-Line Pressure Intensifier
- End pressure up to 800 bar / 11,600 psi
- Multiple intensification ratios available
- Reciprocating - delivers continuous flow during pressure build up
- All high pressure valves are integrated including a p.o. check valve

The MP-L Pressure Intensifier

Ratio (i)	Max. Inlet flow (LPM / GPM)	Outlet Flow Q1 (LPM / GPM)	Outlet Flow Q2 (LPM / GPM)	Max. Supply Pressure (bar / psi)	Max. Output Pressure (bar / psi)
2.0	50.0 / 13.22	5.0 / 1.32	2.0 / 0.52	200 / 2,900	400 / 5,800
3.4	80.0 / 21.16	17.8 / 4.71	13.0 / 3.44	200 / 2,900	680 / 9,860
4.0	80.0 / 21.16	14.7 / 3.89	11.0 / 2.91	200 / 2,900	800 / 11,600
5.0	80.0 / 21.16	11.6 / 3.06	8.0 / 2.33	160 / 2,320	800 / 11,600
7.0	80.0 / 21.16	8.4 / 2.22	6.3 / 1.67	114 / 1,653	800 / 11,600

Weight : 9.0 kgs

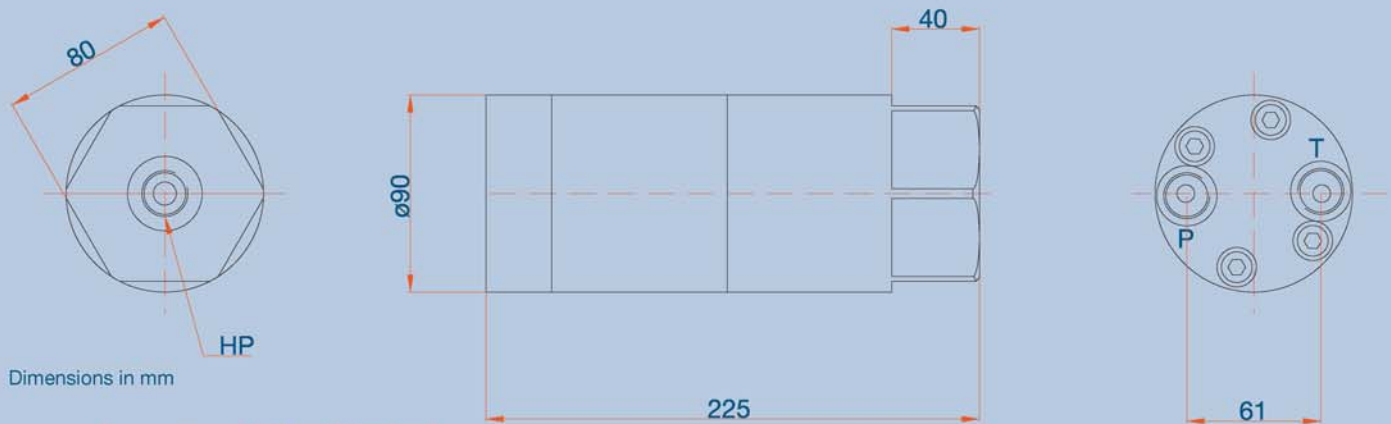

Dimensions in mm

Connections: G1/2" (1/2" BSP)

Ordering code

Intensification				
2.0	3.4	4.0	5.0	7.0

Example

MP-L with intensification 4.0: MP-L-4.0





- In-Line Pressure Intensifier
- End pressure up to 2,000 bar / 29,000 psi (higher pressures possible)
- Multiple intensification ratios available
- Reciprocating - delivers continuous flow during pressure build up
- All high pressure valves are integrated

The MP-2000 Pressure Intensifier

Ratio (i)	Max. Inlet flow (LPM / GPM)	Outlet Flow Q1 (LPM / GPM)	Outlet Flow Q2 (LPM / GPM)	Max. Supply Pressure (bar / psi)	Max. Output Pressure (bar / psi)
7.0	13.0 / 3.40	1.1 / 0.29	0.2 / 0.05	200 / 2,900	1,400 / 20,300
10.0	12.0 / 3.17	0.7 / 0.18	0.2 / 0.05	200 / 2,900	2,000 / 29,000
13.0	10.0 / 2.64	0.5 / 0.13	0.1 / 0.02	200 / 2,900	2,600 / 37,700
16.0	10.0 / 2.64	0.4 / 0.10	0.1 / 0.02	188 / 2,711	3,000 / 43,500

Weight : 2.7 kgs

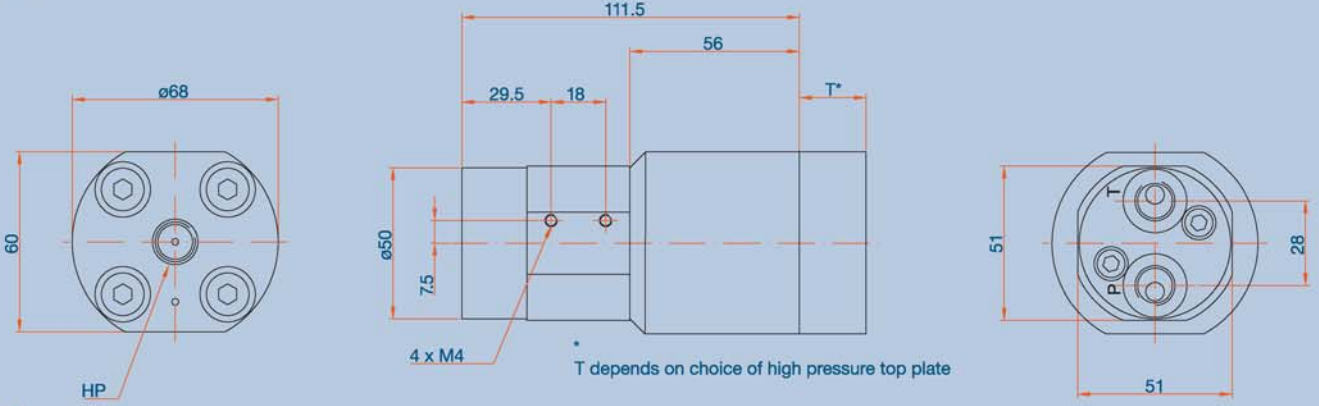

Ordering code
MP-2000 - -

POV		Intensification			
Yes	P	7.0	10.0	13.0	16.0
No	S				

Example
MP-2000 with the POV integrated and intensification 10.0: MP-2000-P-10.0



- In-Line Pressure Intensifier
- End pressures from 1,000 to 4,000 bar / 14,500 to 58,000 psi
- Reciprocating - delivers continuous flow during pressure build up
- All high pressure valves are integrated

The MPL-2000 Pressure Intensifier

1400
4000

Ratio (i)	Max. Inlet flow (LPM / GPM)	Outlet Flow Q1 (LPM / GPM)	Outlet Flow Q2 (LPM / GPM)	Max. Supply Pressure (bar / psi)	Max. Output Pressure (bar / psi)
MPL-1400:					
7.0:1	50.0 / 13.1	8.0 / 2.1	5.9 / 1.5	200 / 3,000	1,400 / 20,300
MPL-2000:					
14.0:1	30.0 / 7.8	5.0 / 1.3	2.9 / 0.8	200 / 3,000	2,800 / 40,600
MPL-4000:					
20.0:1	30.0 / 7.8	4.0 / 1.0	2.0 / 0.5	200 / 3,000	4,000 / 58,000

Weight : 9.0 kgs

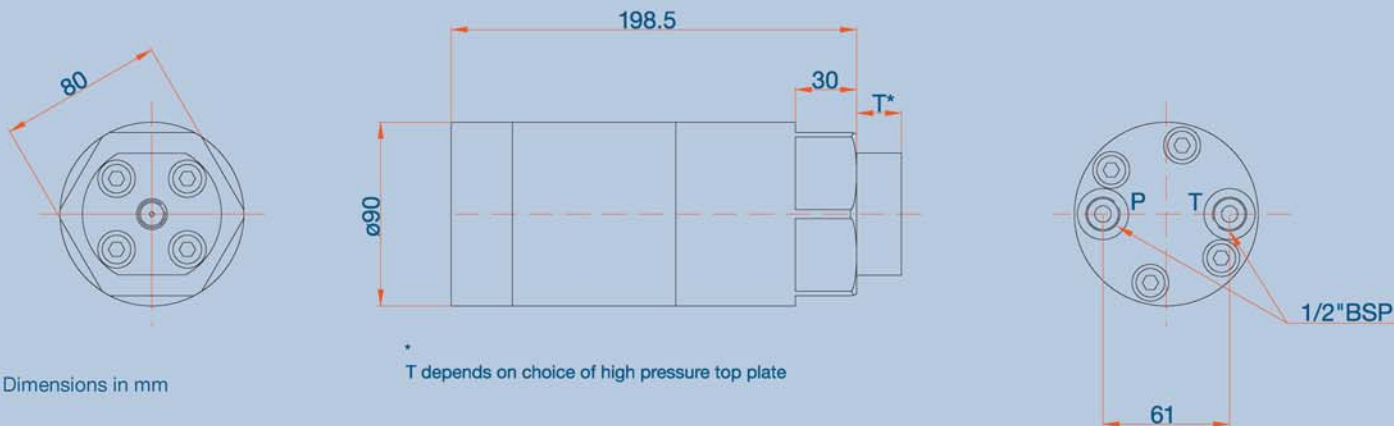

Specials

The MP-T series of hydraulic pressure intensifiers is ideal for making specials, to meet the market demands. Below are two examples on specials made for customers.

The MP-T-R pressure intensifier

is based on the MP-T series, but modified to be inserted in a rotating application, where it rotates at 1,500 rpm, while intensifying a supplied pressure of 30 Bar to 210 Bar.



The MPM-F pressure intensifier

is a made to meet the space requirements of a customer for hydraulic roughnecks in the off shore industry.



Specials and Accessories

Accessories

M-Kit

The M-Kit consists of two mounting brackets, used to fasten the intensifier to a base plate.



Connection Kit

Connection Kits are available for mounting the intensifiers directly to a hydraulic block, The P and T connection is then supplied directly through the Connection Kit, eliminating the need for tubing.



M-Nut

The M-Nut is a M28 x 1.5 Nut used for mounting the MP-T pressure intensifier.



Cetop DO3 / NG6 top plate

The Cetop DO3 / NG6 top plate is for closing the top of the MP-C pressure intensifier.





www.scanwill.com



Scanwill Fluid Power ApS
Roholmsvej 10L
2620 Albertslund / Denmark
Tel +45 74 42 34 50
Fax +45 74 42 34 30
info@scanwill.com



Scan the QR-code and go directly to the internet site of Scanwill Fluid Power ApS

