

CSL2

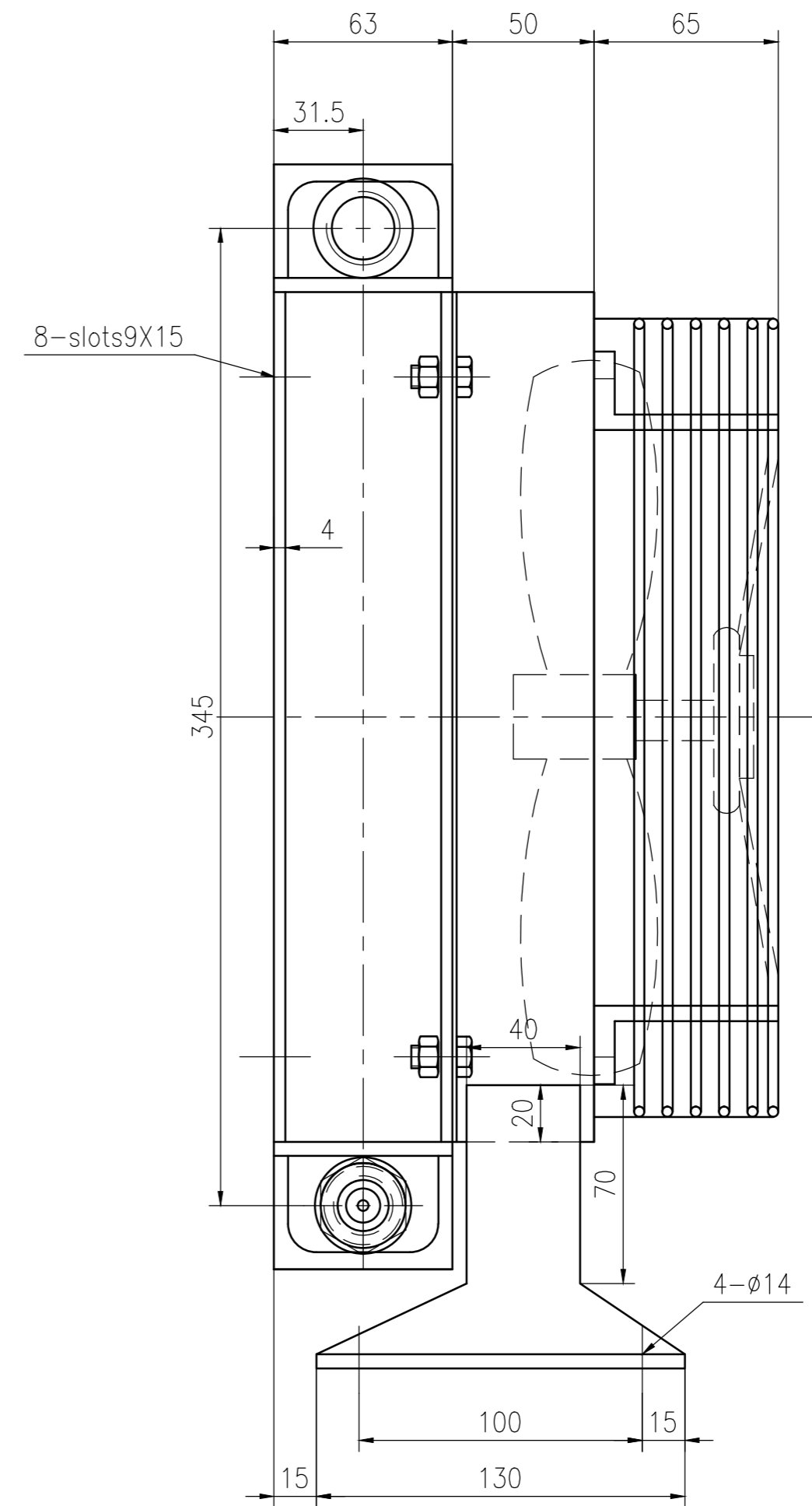
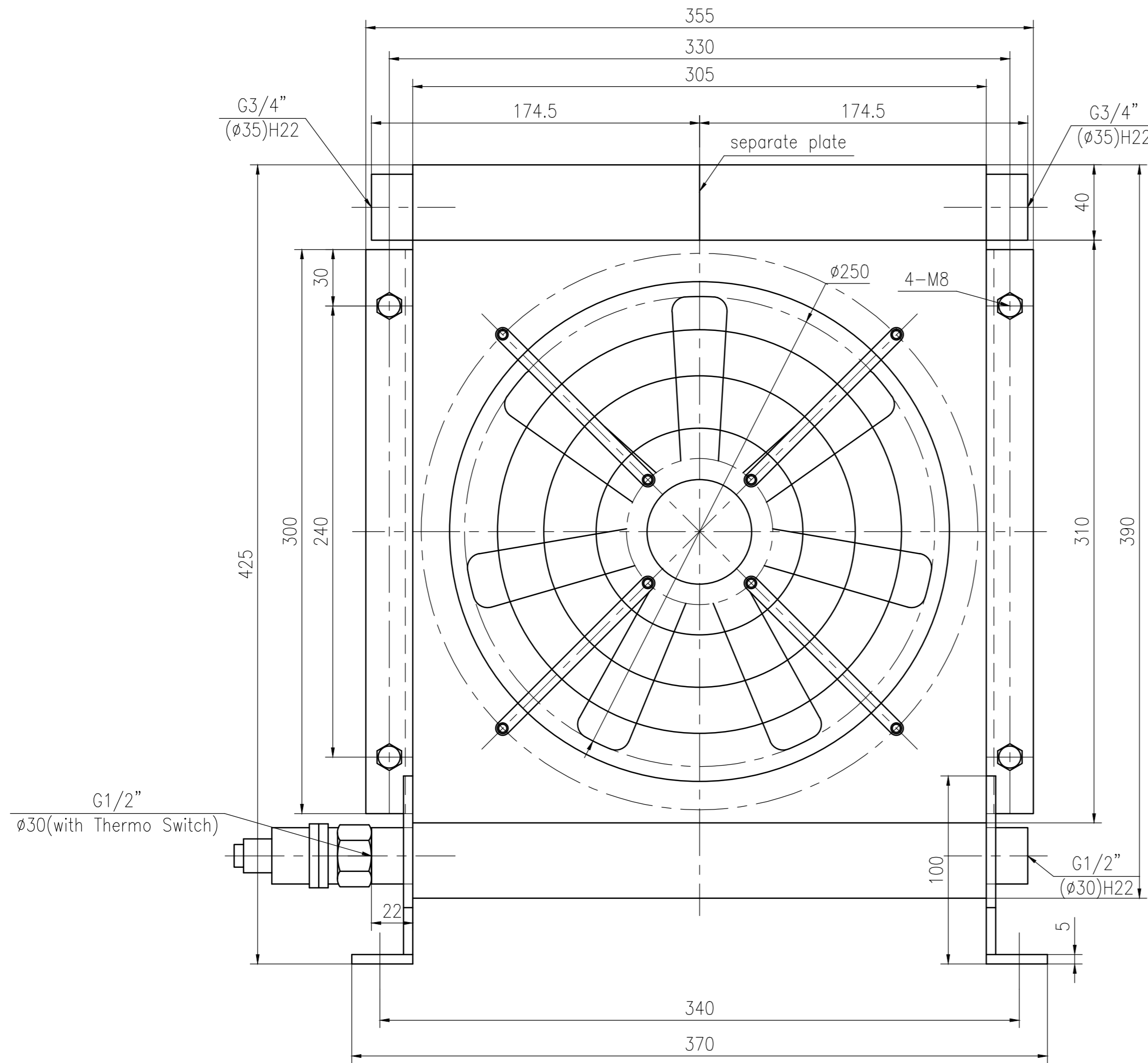

outside fin:95BW2502
inside fin:30JC2002/50

风扇要求:电机220V, 128W
风量1960m³/h

TECH REQUIREMENT

1. This product is made and confirmed according to NB/T47006-2009 technical specification of aluminum Bar-plate heat exchanger.
2. The argon-arc welding seam must be welded completely. There should not be any air vent and crackle in seam. Keep shape beautiful.
3. Water test pressure is 3.0Mpa for 5 minutes and no any leakage is allowed. Air test pressure is 1.0Mpa in the water for 15 minutes and no any leakage is allowed.
4. Appearance should not be knocked against and scratched seriously.
5. Dry up inside, clear appearance. Seal all port, black paint

借通用件登记

描图

校描

旧底图总号

签字

日期

				Gin Stone(wuxi) Heat exchanger Technology Co.,Ltd			
Mark No	Revision No	Signature	Date	Drawing Marking		Weight	Scale
Design		Standard Auditor					1:2
Reviewed by		Date		Total Page	Page of		
Technics							CSL2

oil cooler

CSL2