

LTSJ

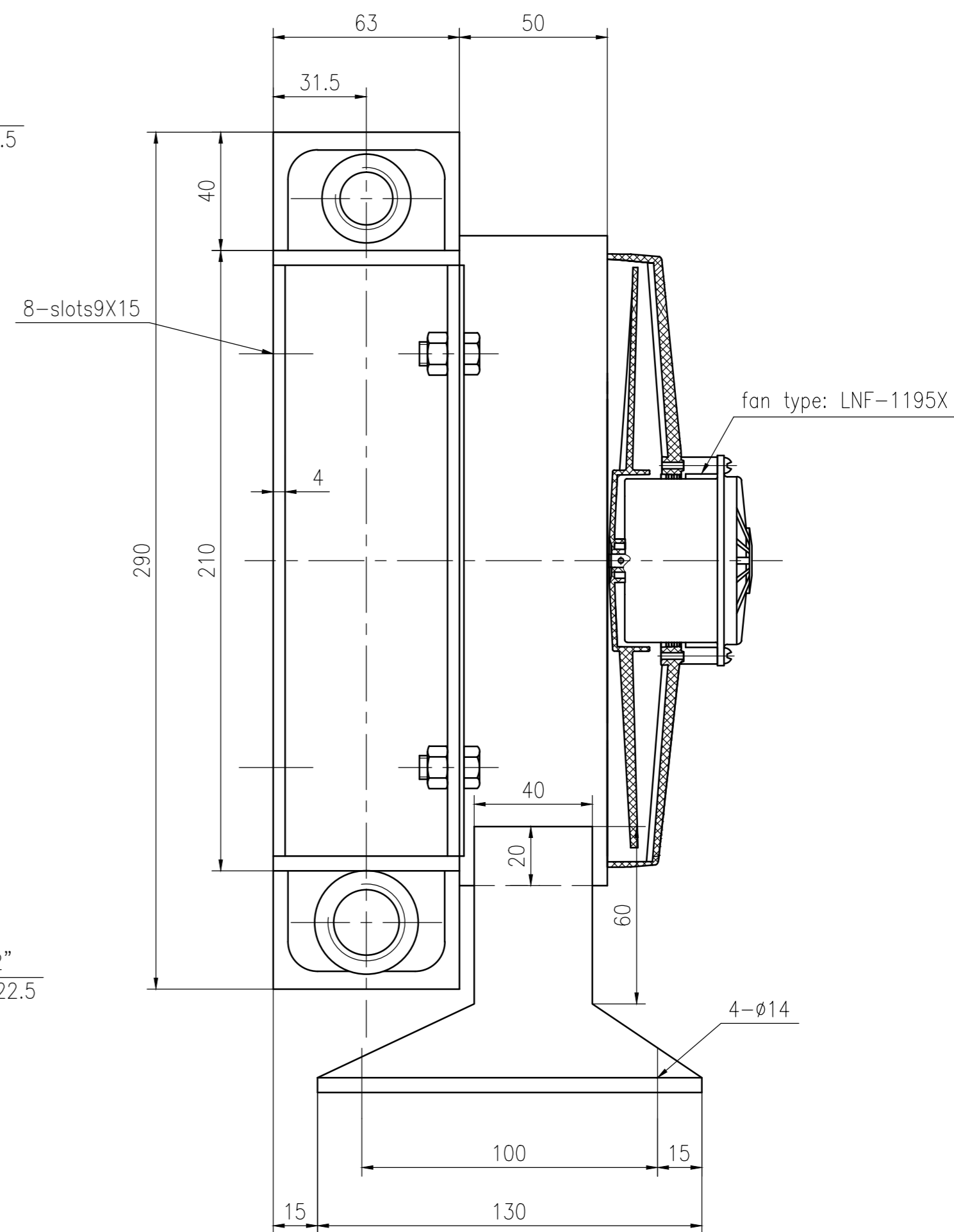
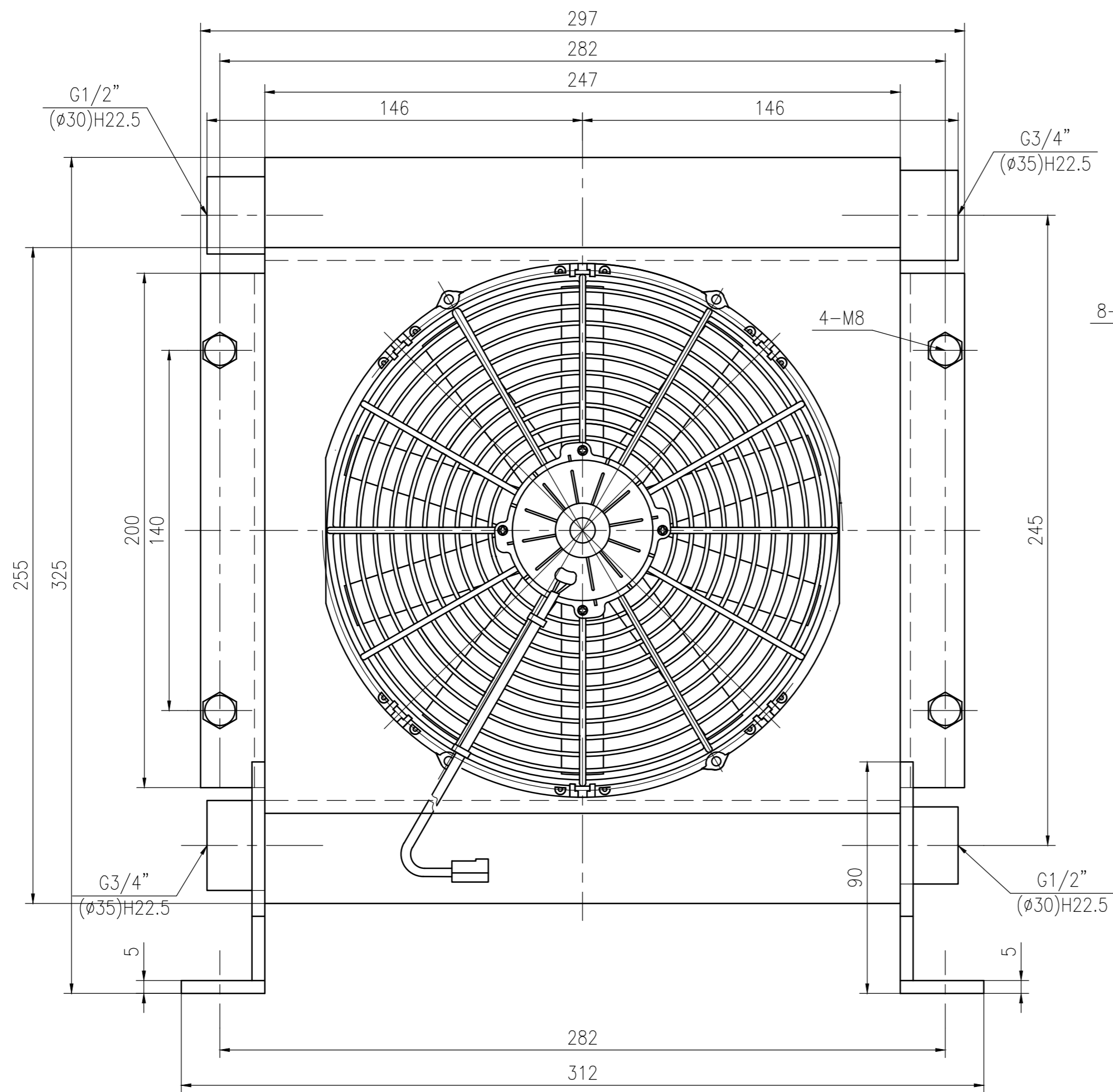

TECH REQUIREMENT

1. This product is made and confirmed according to NB/T47006-2009 technical specification of aluminum Bar-plate heat exchanger.
2. The argon-arc welding seam must be welded completely. There should not be any air vent and crackle in seam. Keep shape beautiful.
3. Water test pressure is 3.0Mpa for 5 minutes and no any leakage is allowed. Air test pressure is 1.0Mpa in the water for 15 minutes and no any leakage is allowed.
4. Appearance should not be knocked against and scratched seriously.
5. Dry up inside, clear appearance. Seal all port, black paint

借通用件登记

描图

校描

旧底图总号

签字

日期

				Gin Stonelwuxi Heat exchanger Technology Co., Ltd		
				oil cooler		
Mark No.	Revision No.	Signature	Date	Drawing Marking	Weight	Scale
Design		Standard				1:1.5
Reviewed by		Auditor		Total Page	Page of	
Technics		Date				

CSL1