

R 15 • R 25

COMPLETE PLASTIC RESERVOIRS



Function

- The R 15 / R 25 complete plastic reservoirs combine a solid rotational molded plastic shell with an HF 547-10 filter and an HL 91-10 level indicator.
- On request, an HF 431-10 / HF 434-10 / HF 437-10 suction filter and an EP hand pump can be added to the reservoir.
- This module is ready to be installed into the hydraulic circuit without any additional operations, reducing maintenance costs.
- Easy installing with 4 threaded holes in the back to guarantee a stable fixing.
- Excellent resistance to corrosion.
- The oil baffle creates a division between the return line oil and suction line oil, preventing bubbling going through the circuit.



Technical Data

• Reservoir Volume	V _{MAX}	R 15 - 15 L R 25 - 25 L
• Temperature	T _{MAX}	-4 ÷ 176 °F (-20 ÷ 80 °C)
• Fluid Compatibility		HH - HL - HM - HR - HV - HG - HFAE - HFAS
• Material		XLPE Cross-linked polyethylene

DIMENSIONS

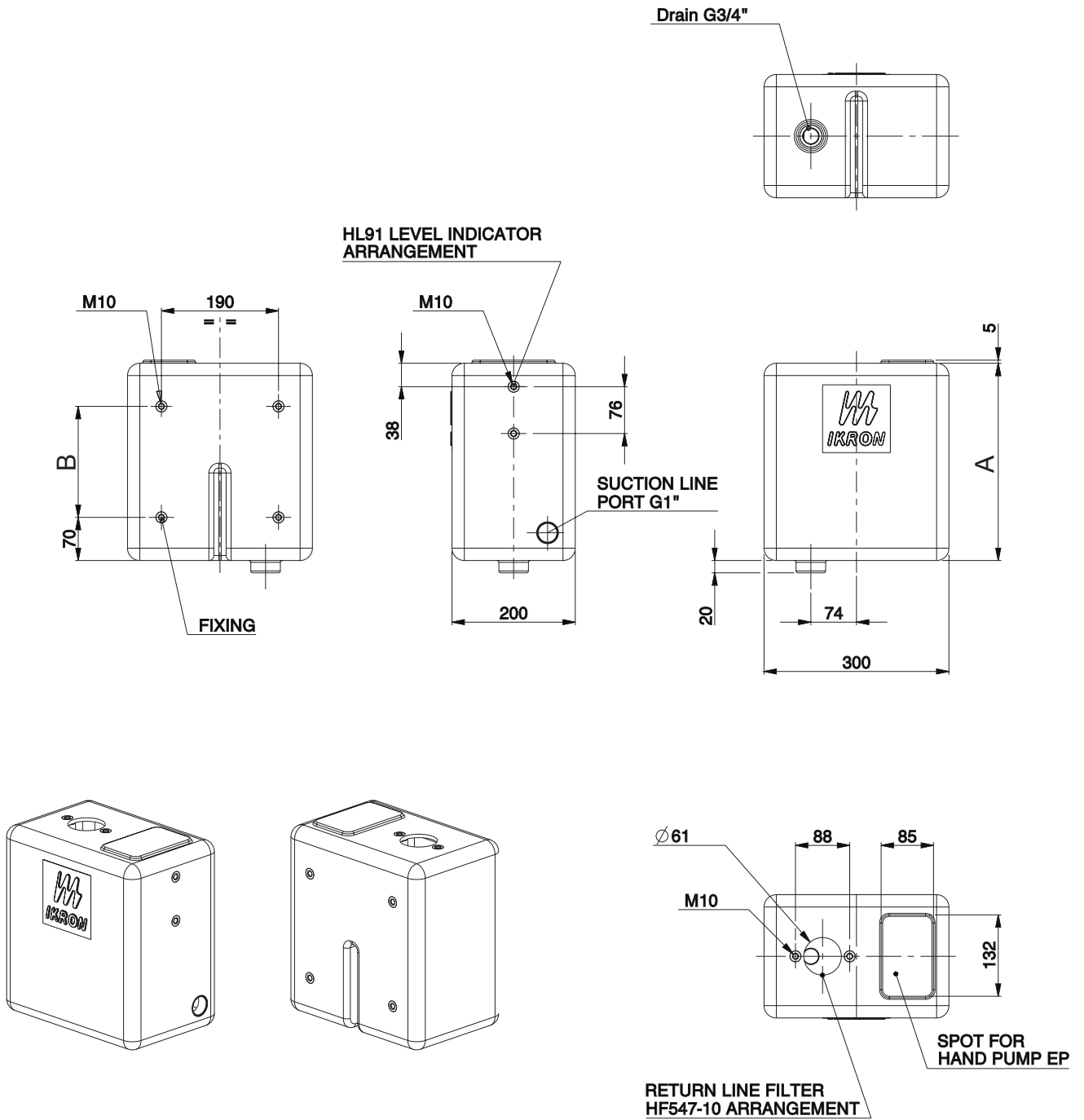

Reservoir	Weight	A	B
	kg	mm	mm
R 15	3,2	320	180
R 25	4,5	520	380

EXPLODED VIEW



BUILD YOUR RESERVOIR

Example

1	2	3	4 ^o	5 ^o
R15	- HHD30916	- HHI03800	- HHB99073 ^o	- 06003208 ^o

1 - Plastic Reservoir

Description	Code
15 L Capacity	R15
25 L Capacity	R25

2 - Tank Top Filter*

Description	Code
HF 547-10...	HHDxxxxx

*Refer to our HF 547 Return Line Filter catalog

3 - Level Indicator*

Description	Code
HL 91-10...	HHIxxxxx

*Refer to our Accessories catalog

4 - Suction Filter*

Description	Code
HF 431 / 434 / 437...	HHBxxxxx
No Suction Filter	omit

*Refer to our HF 431 / 434 / 437 Suction Line Filters catalog

5 - Hand Pump*

Description	Code
EP...	0600xxxx
No Hand Pump	omit

*Refer to our UpEasy EP Hand Pumps catalog

^oon request

For special requirements please contact our Tech Dept

